

COMPONENT PARTS

Oil Pump Body

COMPONENTS

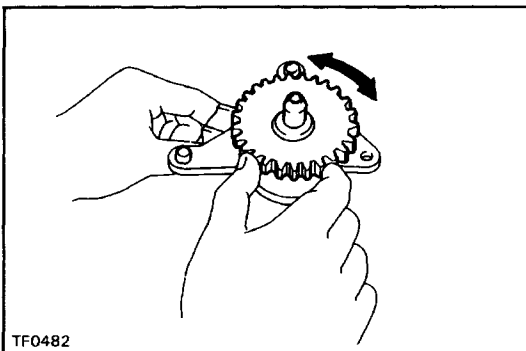
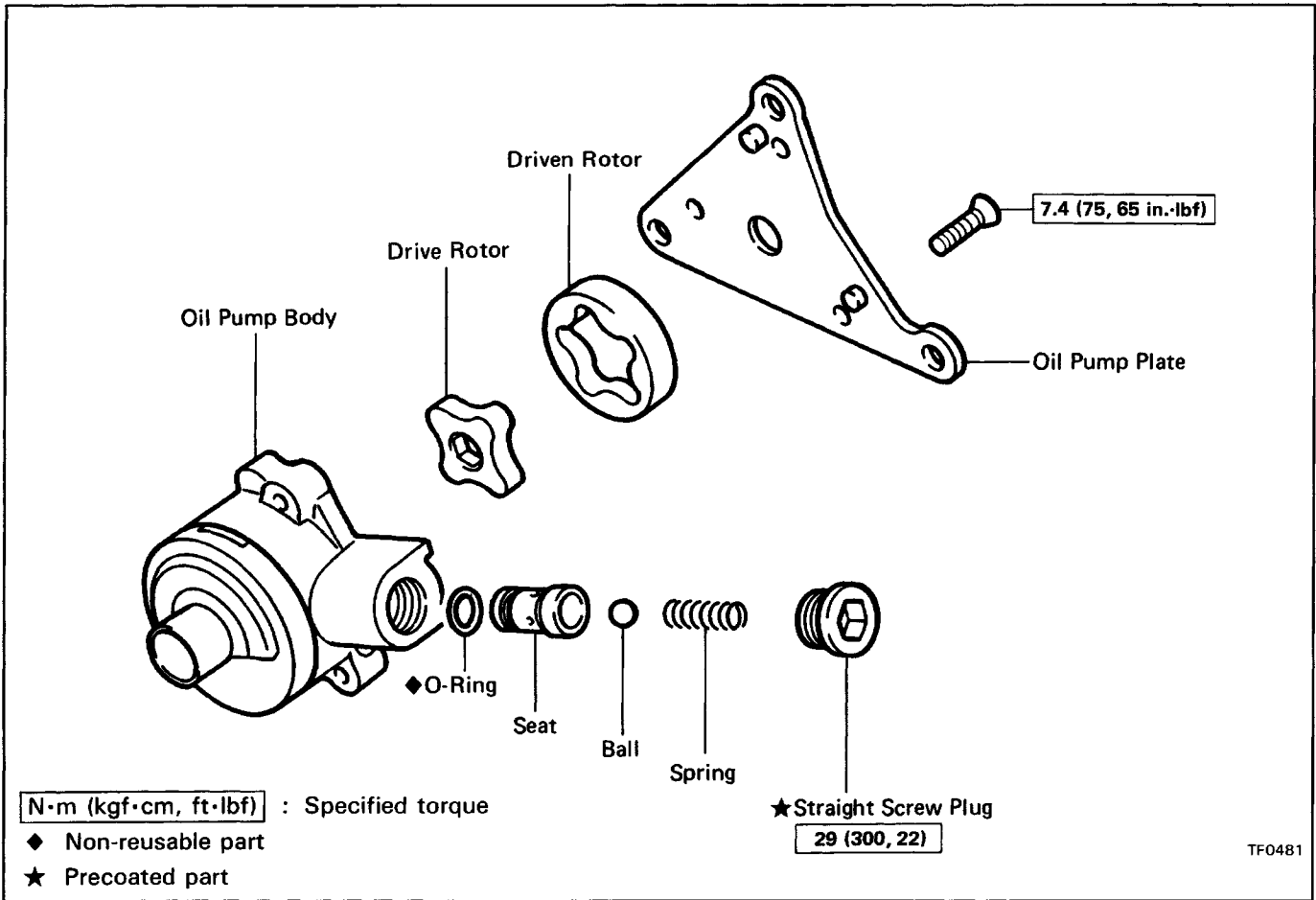

DISASSEMBLY OF OIL PUMP BODY

1. CHECK OPERATION OF OIL PUMP

Install the oil pump drive gear to the drive rotor, check that the drive rotor turns smoothly.

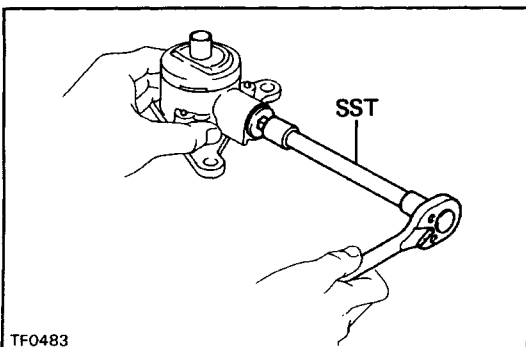

2. REMOVE STRAIGHT SCREW PLUG, SPRING, BALL AND SEAT

(a) Using SST, remove the straight screw plug.
SST 09043-38100

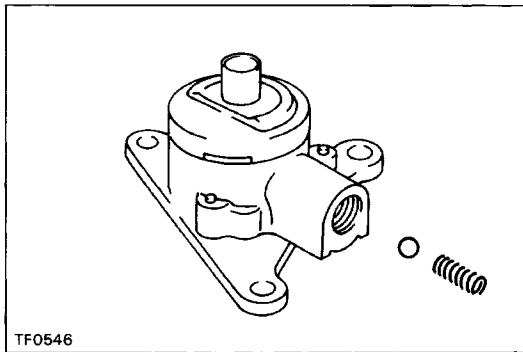

(b) Using a magnetic finger, remove the spring and ball.

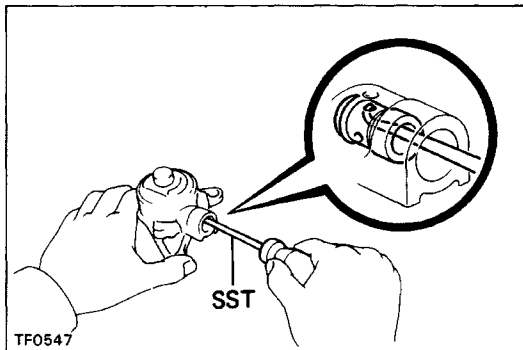

(c) Using SST, pull out the seat.

SST 09921-00010

(d) Remove the O-ring from the seat.

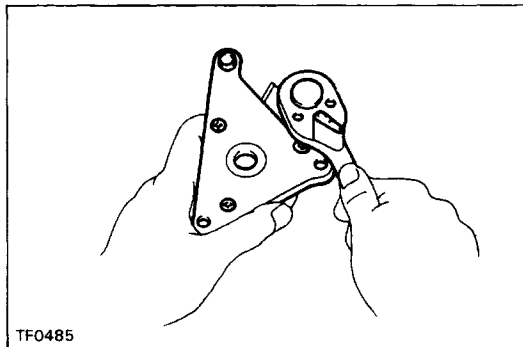

3. REMOVE OIL PUMP PLATE

(a) Using a torx socket wrench, unscrew the three torx screws.

(Torx socket wrench T30 09042-00010)

(b) Remove the oil pump plate.

4. REMOVE DRIVE ROTOR AND DRIVEN ROTOR

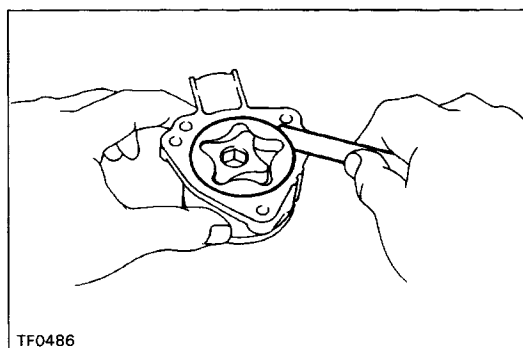

INSPECTION OF OIL PUMP BODY

1. CHECK BODY CLEARANCE OF DRIVEN ROTOR

Push the driven rotor to one side of the body.

Using a feeler gauge, measure the clearance.

Standard clearance: 0.10 – 0.16 mm

(0.0039 – 0.0063 in.)

Maximum clearance: 0.16 mm (0.0063 in.)

If the clearance exceeds the limit, replace the drive rotor, driven rotor or pump body.

2. CHECK TIP CLEARANCE OF BOTH ROTORS

Using a feeler gauge, measure the clearance between both rotor tips.

Standard clearance: 0.08 – 0.16 mm

(0.0031 – 0.0063 in.)

Maximum clearance: 0.16 mm (0.0063 in.)

If the clearance exceeds the limit, replace the drive rotor, driven rotor or pump body.

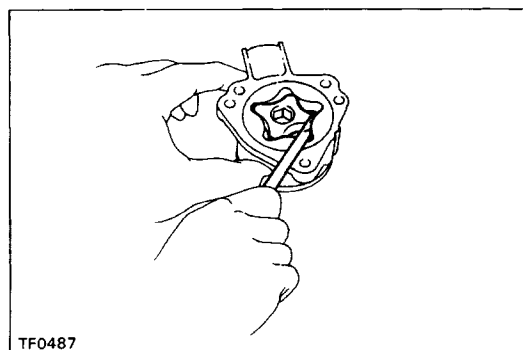

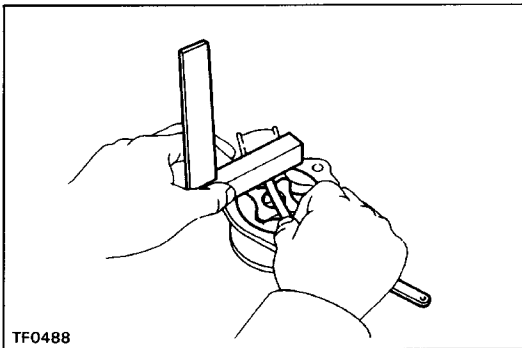

3. CHECK SIDE CLEARANCE OF BOTH ROTORS

Using a steel straight edge and feeler gauge, measure the clearance between the rotors and straight edge.

Standard clearance: 0.03 – 0.08 mm

(0.0012 – 0.0031 in.)

Maximum clearance: 0.08 mm (0.0031 in.)

If the clearance exceeds the limit, replace the drive rotor, driven rotor or pump body.

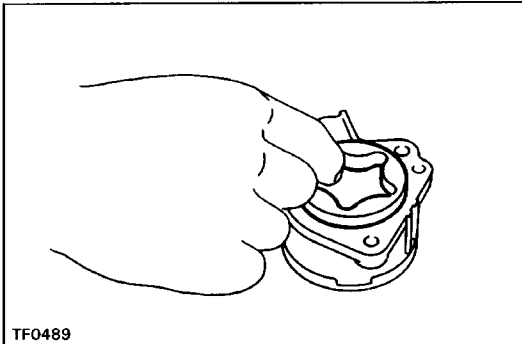

ASSEMBLY OF OIL PUMP BODY

1. INSTALL OIL PUMP DRIVE ROTOR AND DRIVEN ROTOR

- (a) Apply gear oil to the both rotors.
- (b) Install the driven rotor.

- (c) Install the drive rotor.

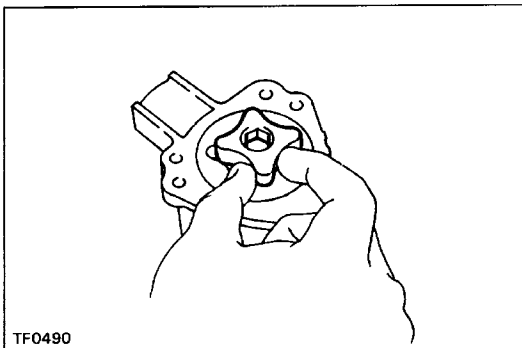

2. INSTALL OIL PUMP PLATE

- (a) Install the oil pump plate.
- (b) Using a torx socket wrench, tighten the three torx screws.

(Torx socket wrench T30 09042-00010)

Torque: 7.4 N-m (75 kgf-cm, 65 in.-lbf)

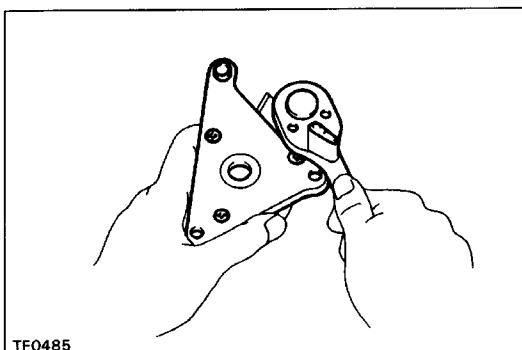

3. INSTALL SEAT, BALL, SPRING AND STRAIGHT SCREW PLUG

- (a) Install a new O-ring to the seat.
- (b) Install the seat, ball and spring.

HINT: When installing the seat, push the seat until it touches the bottom of the hole in the body.

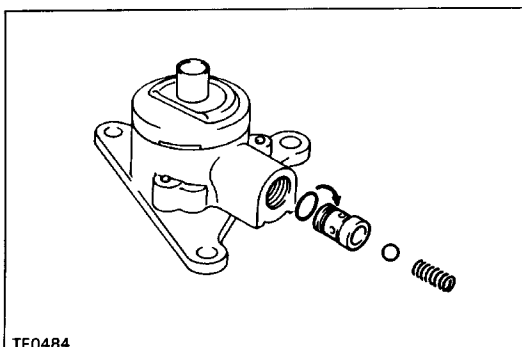

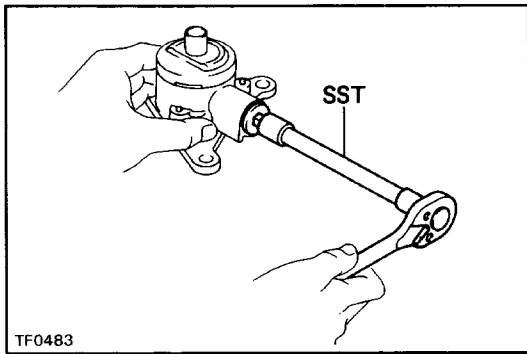

(c) Apply liquid sealer to the plug.

**Sealant: Part No. 08833-00080, THREE BOND 1344,
LOCTITE 242 or equivalent**

(d) Using SST, torque the plug.

SST 09043-38100

Torque: 29 N-m (300 kgf-cm, 22 ft-lbf)

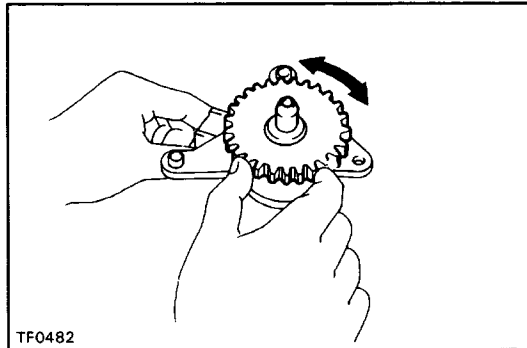

4. CHECK OPERATION OF OIL PUMP

Install the oil pump drive gear to the drive rotor, check that the drive rotor turns smoothly.