

## COMPONENT PARTS INSTALLATION

### BASIC SUBASSEMBLY REASSEMBLY

HINT: Coat all of the sliding and rotating surface with gear oil before assembly.

#### 1. INSTALL OUTPUT SHAFT TO INTERMEDIATE PLATE

(a) Before installing the output shaft, use SST to remove the counter gear center bearing outer race.

SST 09608-35014 (09608-06020, 09608-06090)

HINT: Install the outer race after installing the counter gear.

(b) Install the output shaft into the intermediate plate by pulling on the output shaft and tapping on the intermediate plate.

#### 2. INSTALL INPUT SHAFT AND COUNTER GEAR

(a) Apply gear oil to the needle roller bearing.

(b) Install the needle roller bearing to the input shaft.

(c) Install the input shaft and counter gear together.

(d) Using SST and a hammer, install the counter gear center bearing outer race.

SST 09316-60010 (09316-00010)

HINT: Be careful not to damage the bearing rollers.

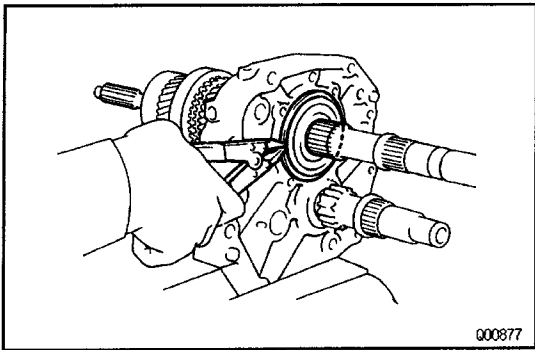

000877

### 3. INSTALL BEARING RETAINER

- (a) Using a snap ring expander, install the bearing snap ring.

HINT: Be sure the snap ring is flush with the intermediate plate surface.

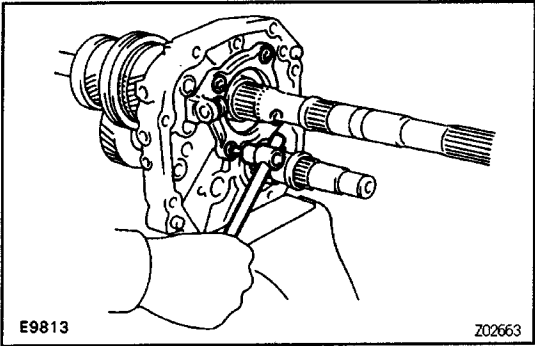

E9813

Z02663

- (b) Using a torx socket wrench, install and torque the screws.

Torx wrench T40 09042-00020

Torque: 18 N-m (185 kgf-cm, 13 ft-lbf)

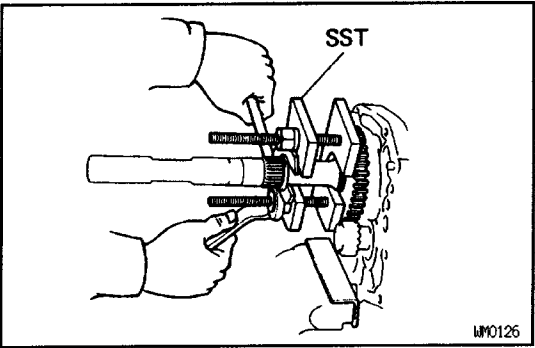

WM0126

### 4. INSTALL REVERSE GEAR

Using SST, install the reverse gear.

SST 09312-20011 (09313-00030, 09313-00040, 09313-00050)

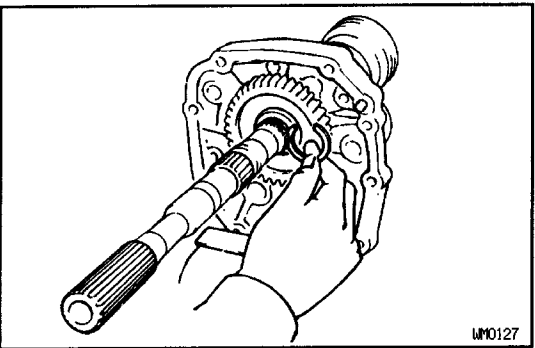

WM0127

### 5. INSTALL SNAP RING

- (a) Select a snap ring that will allow minimum axial play.

Mark	Thickness mm (in.)
5	2.25–2.30 (0.0886–0.0906)
11	2.30–2.35 (0.0906–0.0925)
12	2.35–2.40 (0.0925–0.0945)
13	2.40–2.45 (0.0945–0.0965)
14	2.45–2.50 (0.0965–0.0984)
15	2.50–2.55 (0.0984–0.1004)
16	2.55–2.60 (0.1004–0.1024)
17	2.61–2.66 (0.1028–0.1047)
18	2.67–2.72 (0.1051–0.1071)
19	2.73–2.78 (0.1075–0.1094)
20	2.79–2.84 (0.1098–0.1118)
21	2.85–2.90 (0.1122–0.1142)
22	2.91–2.96 (0.1146–0.1165)
23	2.97–3.02 (0.1169–0.1189)

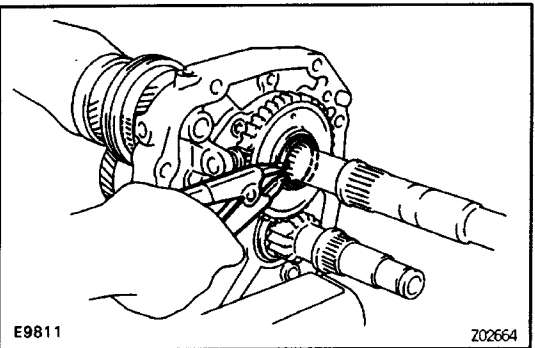

E9811

Z02664

- (b) Using a snap ring expander, install the snap ring.

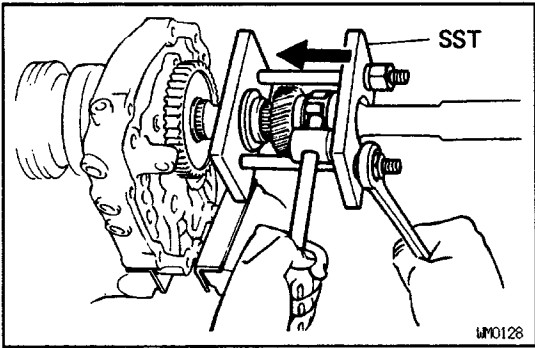

**6. INSTALL FIFTH GEAR AND OUTPUT SHAFT REAR BEARING**

Using SST, install the 5th gear and rear bearing. SST 09312-20011 (09313-00010, 09313-00030, 09313-00040, 09313-00050)

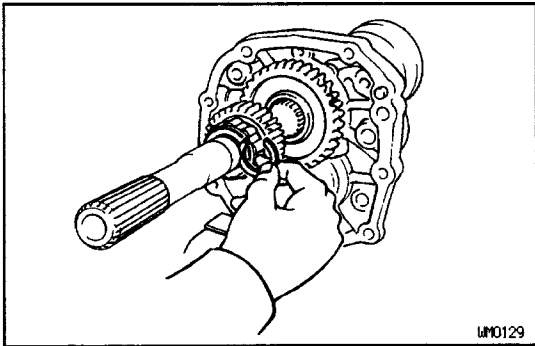

**7. INSTALL SNAP RING**

(a) Select a snap ring that will allow minimum axial play.

Mark	Thickness mm (in.)
8	2.31 – 2.36 (0.0909 – 0.0929)
9	2.37 – 2.42 (0.0933 – 0.0953)
10	2.43 – 2.48 (0.0957 – 0.0976)
11	2.49 – 2.54 (0.0980 – 0.1000)
12	2.55 – 2.60 (0.1004 – 0.1024)
13	2.61 – 2.66 (0.1028 – 0.1047)
14	2.68 – 2.73 (0.1055 – 0.1098)
15	2.74 – 2.79 (0.1079 – 0.1098)

(b) Using a screwdriver and hammer, tap in the snap ring.

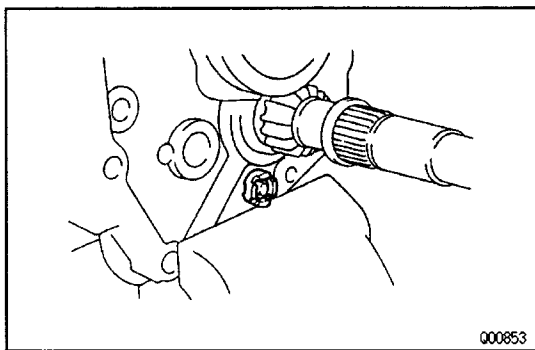
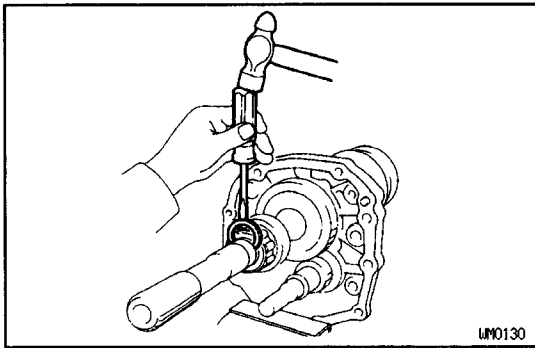

**8. INSTALL REAR MAGNET**

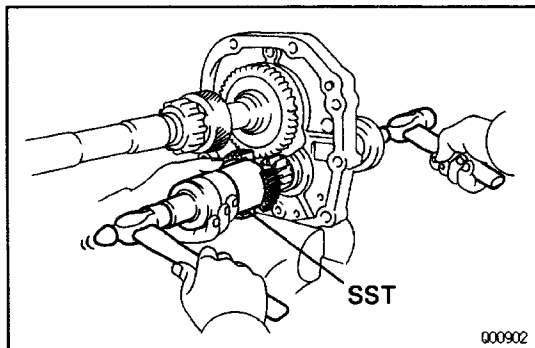

**9. INSTALL NO.3 CLUTCH HUB**

Using SST and a hammer, drive in No.3 clutch hub. SST 09316-60010 (09316-00010, 09316-00070)

HINT: When installing the clutch hub, support the counter shaft in front with a 3-5 lb hammer or equivalent.

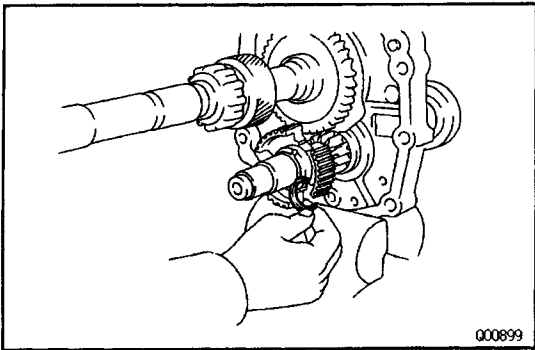

**10. INSTALL SNAP RING**

(a) Select a snap ring that will allow minimum axial play.

Mark	Thickness mm (in.)
2	2.06–2.11 (0.0811–0.0831)
3	2.12–2.17 (0.0835–0.0854)
4	2.18–2.23 (0.0858–0.0878)
5	2.24–2.29 (0.0882–0.0902)

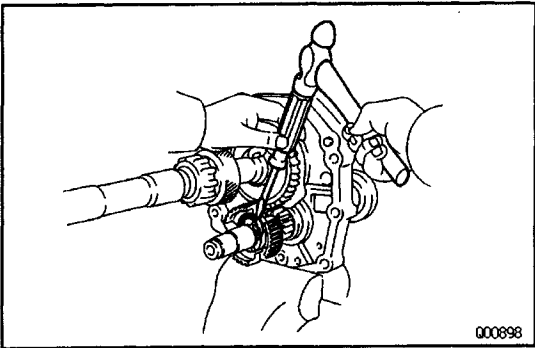

(b) Using a screwdriver and hammer, tap in the snap ring.

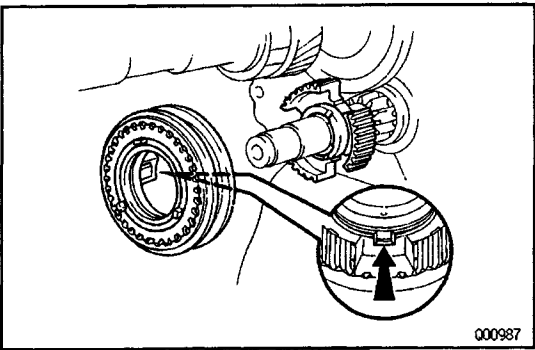

**11. INSTALL NO.3 HUB SLEEVE ASSEMBLY**

- (a) Check for reverse synchronizer pull ring position.
- (b) Install the No.3 hub sleeve assembly to the No.3 clutch hub.

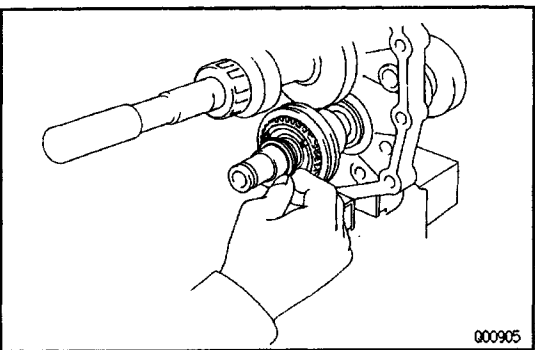

**12. INSTALL SPACER, NEEDLE ROLLER BEARING AND COUNTER FIFTH GEAR**

- (a) Install the spacer.
- (b) Apply gear oil to the needle roller bearing.

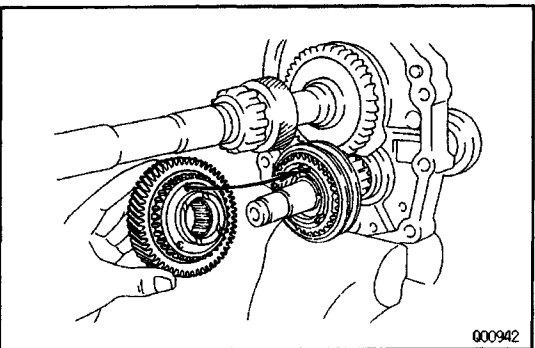

- (c) Install the needle roller bearing to the counter fifth gear.
- (d) Install the counter 5th gear with 5th gear gaps aligned with synchronizer corn ring pin.

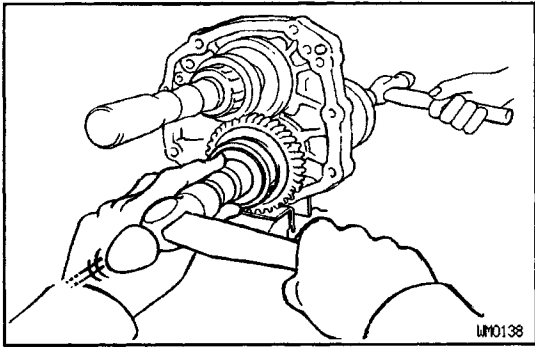

**13. INSTALL SPACER AND BEARING**

- (a) Install the spacer.
- (b) Using a socket wrench and hammer, drive in the bearing.

HINT: When driving in the bearing, support the counter shaft in front with a 3–5 lb hammer or equivalent.

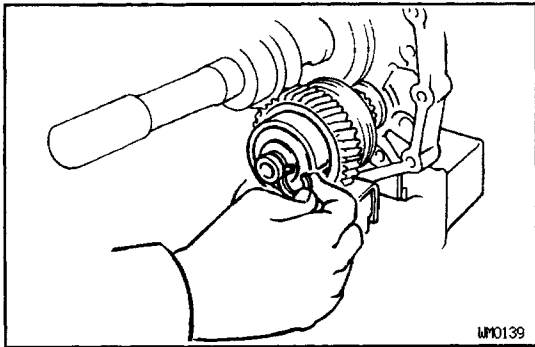

**14. INSTALL SNAP RING**

- (a) Select a snap ring that will allow minimum axial play.

Mark	Thickness mm (in.)
1	1.90–1.95 (0.0748–0.0768)
2	1.96–2.01 (0.0772–0.0791)
3	2.02–2.07 (0.0795–0.0815)
4	2.08–2.13 (0.0819–0.0839)
5	2.14–2.19 (0.0843–0.0862)
6	2.20–2.25 (0.0866–0.0886)
7	2.26–2.31 (0.0890–0.0909)

- (b) Using a snap ring expander, install the snap ring.

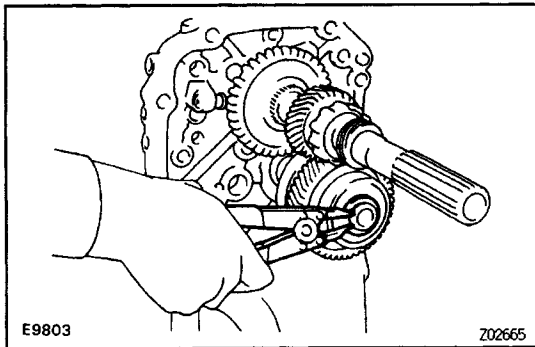

**15. INSPECT COUNTER FIFTH GEAR THRUST CLEARANCE**

Using a feeler gauge, measure the counter 5th gear thrust clearance.

**Standard clearance:**

**0.10–0.41 mm (0.0039–0.0161 in.)**

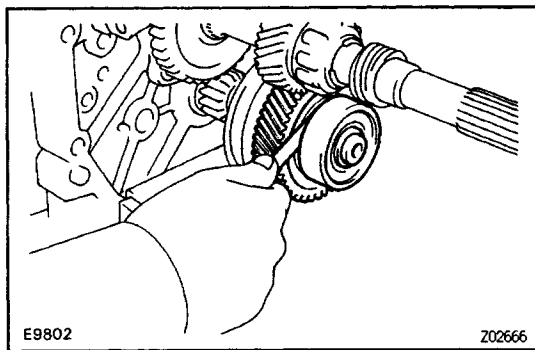

**16. INSTALL SPEED SENSOR DRIVE GEAR**

- (a) Put a clip on the output shaft and install the drive gear clip into the slot.
- (b) Slide the drive gear with clip and fit the clip into the holes.

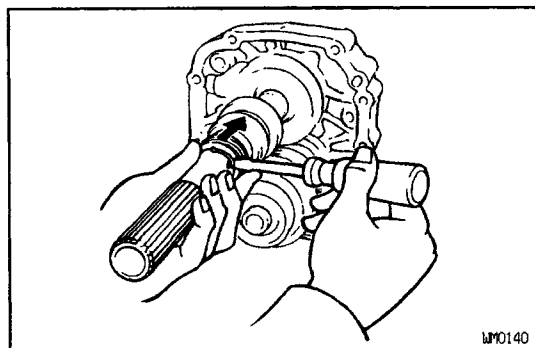

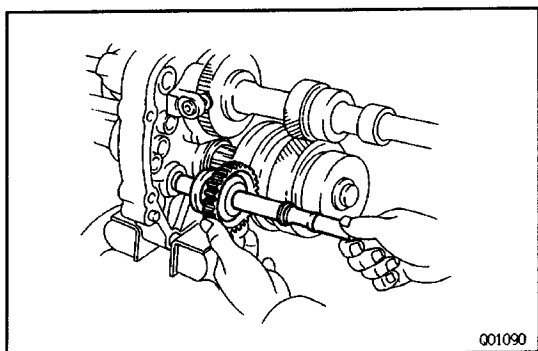

001090

## 17. INSTALL SHIFT FORKS, SHIFT FORK SHAFTS AND REVERSE IDLER GEAR

(a) Install the reverse idler gear and shaft.

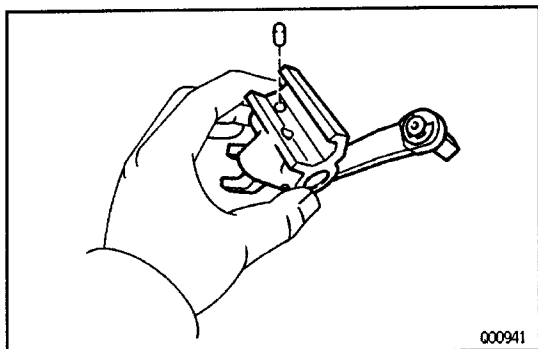

000941

(b) Install the No.3 shift fork, No.3 fork shaft and reverse shift arm.

- Coat the pin with MP grease and insert it into the reverse shift head hole.
- Install the No.3 shaft through the No.3 shift fork and reverse shift arm.
- Align the No.3 shift fork with the No.3 hub sleeve groove, put the reverse shift arm into the pivot of bearing retainer and align the reverse shift arm show with the reverse idler gear groove. Install No.3 the shift fork shaft to the intermediate plate.

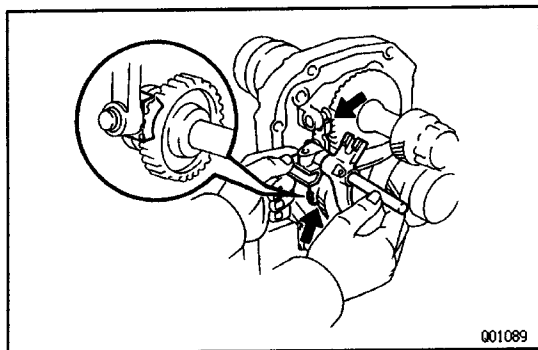

001089

(c) Install the No.4 shift fork shaft.

- Push the pin, which was installed into the reverse shift arm hole, into the groove of No.3 shift fork shaft.

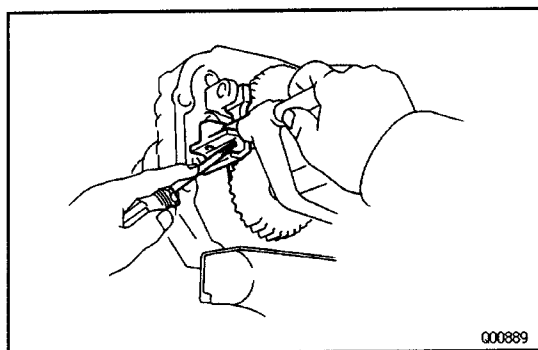

000889

- Install the shift fork shaft No.4 to the intermeddlate plate.

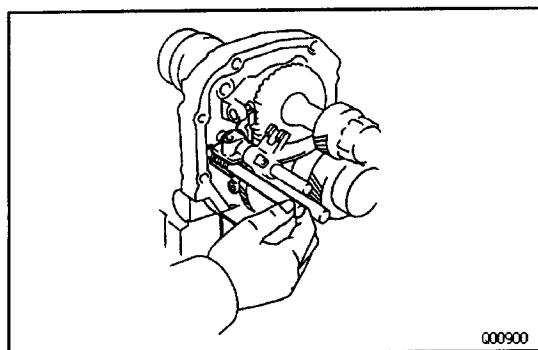

000900

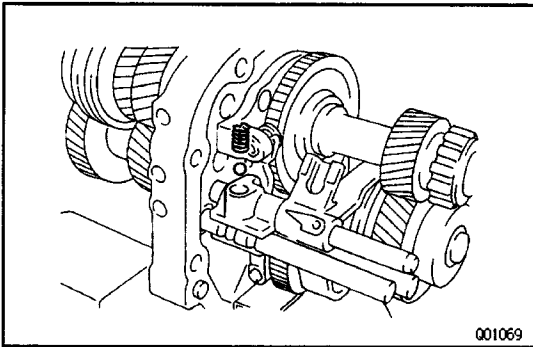

(d) Install the ball and spring.

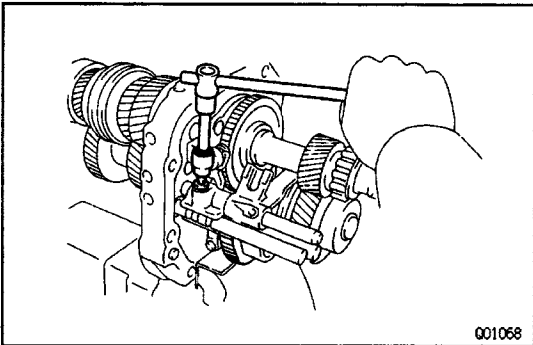

(e) Apply sealant to the plug.

**Sealant:**

**Part No.08833-00080, THREE BOND 1344, LOC-TITE 242 or equivalent**

(f) Using a hexagon wrench, install and torque the plug.  
**Torque: 25 N-m (250 kgf-cm, 18 ft-lbf)**

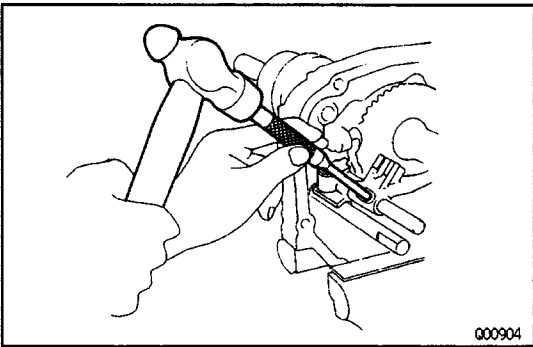

(g) Using a pin punch and hammer, drive in the slotted spring pin until it is flush with the No.3 shift fork.

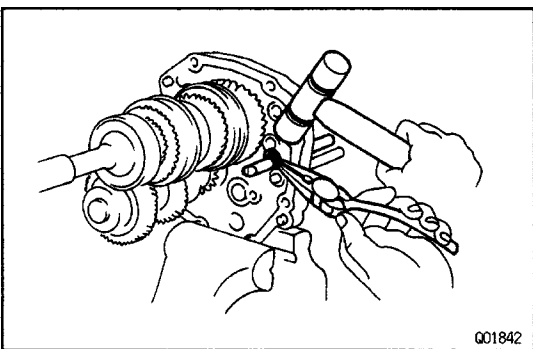

(h) Install the snap ring to the No.3 fork shaft.

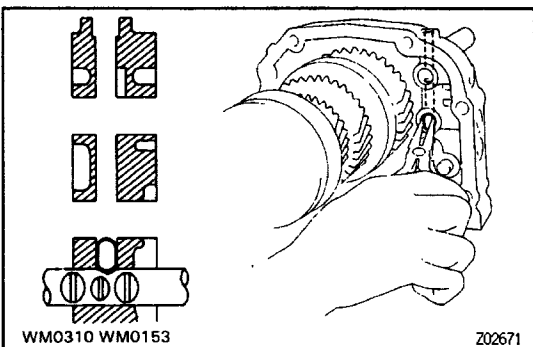

(i) Apply MP grease to the No.3 interlock pin and install the pin into the intermediate plate hole.

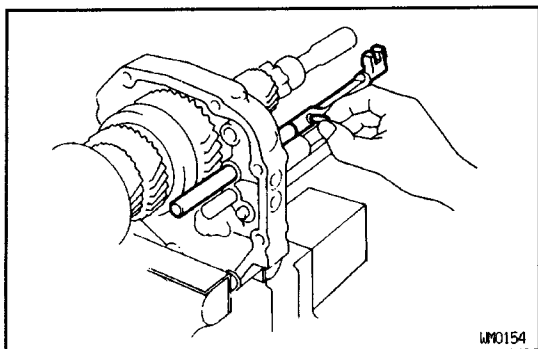

- (j) Install the No.2 shift fork and fork shaft.
- Apply MP grease to No.2 interlock pin and install the pin into the shaft hole.

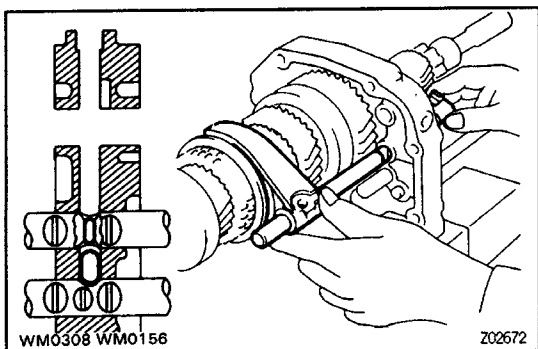

- Place the No.2 shift fork into the groove of No.2 hub sleeve.
- Install the No.2 fork shaft to the shift fork through the intermediate plate.

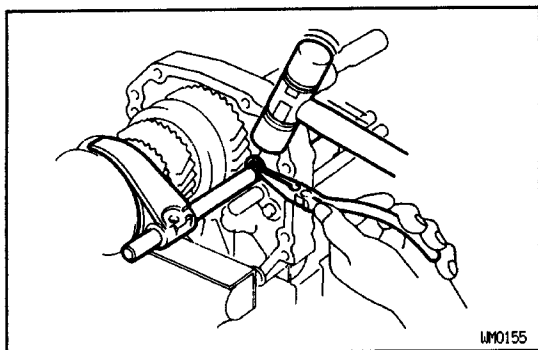

- (k) Install the snap ring to the No.2 fork shaft.

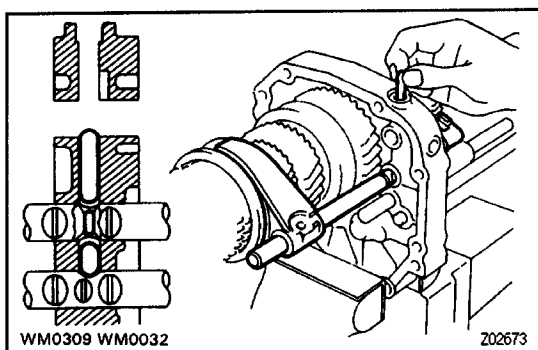

- (l) Apply MP grease to the No.2 interlock pin and install the pin into the intermediate plate.

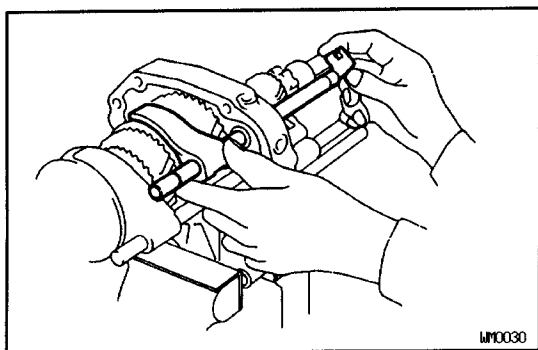

- (m) Install the No.1 shift fork and fork shaft.
- Install the No.1 shift fork into the groove of No.1 hub sleeve.
  - Install the No.1 fork shaft to the shift fork through the intermediate plate.



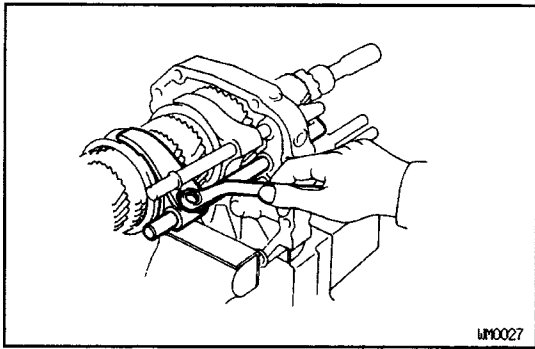

- (n) Install and torque the No.1 and No.2 shift fork set bolts.

**Torque: 20 N-m (200 kgf.cm, 14 ft-lbf)**

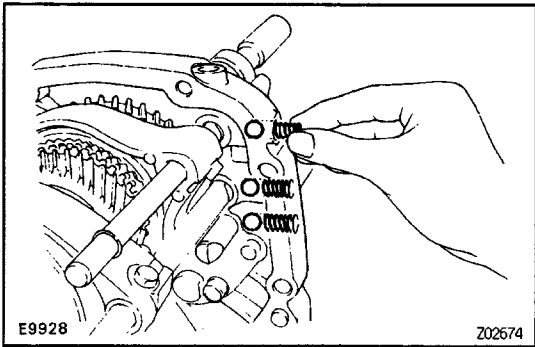

## 18. INSTALL LOCKING BALL AND SPRING

- (a) Install the balls and spring into each hole.

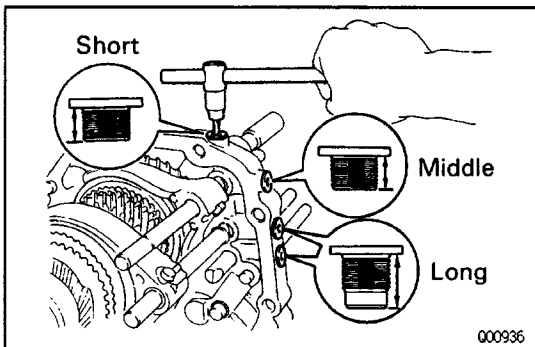

- (b) Apply liquid sealer to the plug threads.

**Sealant:**

**Part No.08833-00080, THREE BOND 1344, LOC-TITE 242 or equivalent**

- (c) Using a hexagon wrench, install the torque the four plugs.

**Torque: 25 N-m (250 kgf-cm, 18 ft-lbf)**

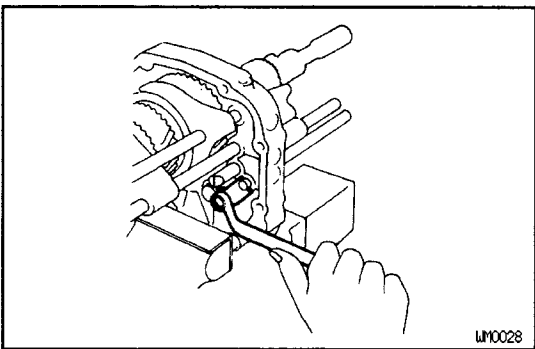

## 19. INSTALL REVERSE IDLER GEAR SHAFT STOPPER

Install the reverse idler gear shaft stopper and torque the bolt.

**Torque: 25 N-m (250 kgf-cm, 18 ft-lbf)**

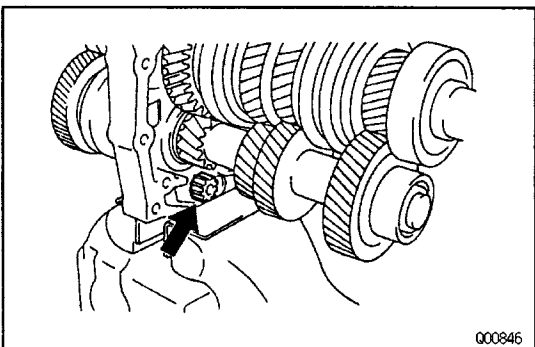

## 20. INSTALL FRONT MAGNET

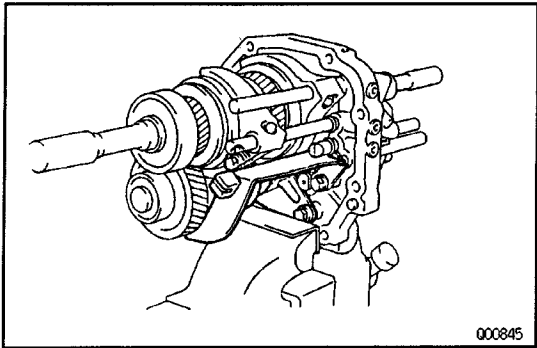

**21. INSTALL OIL SEPARATOR**

Install the oil receiver and torque the two bolts.

**Torque: 18 N-m (185 kgf-cm, 13 ft-lbf)**

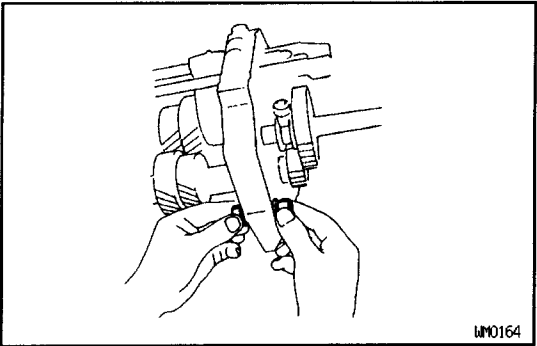

**22. DISMOUNT INTERMEDIATE PLATE FROM VISE**

- (a) Dismount the intermediate plate from the vise.
- (b) Remove the bolts, nuts, plate washers and gasket.

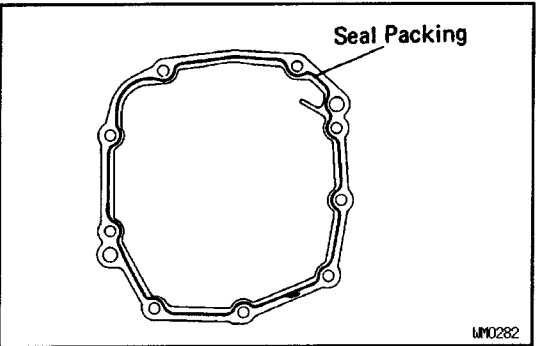

**23. INSTALL TRANSMISSION CASE TO INTERMEDIATE PLATE**

- (a) Remove the any packing material and be careful not to drop oil on the contacting surface of the transmission case or intermediate plate.
- (b) Apply seal packing to the transmission case as shown.

**Seal packing:**

**Part No. 08826 – 00090, THREE BOND 1281 or equivalent**

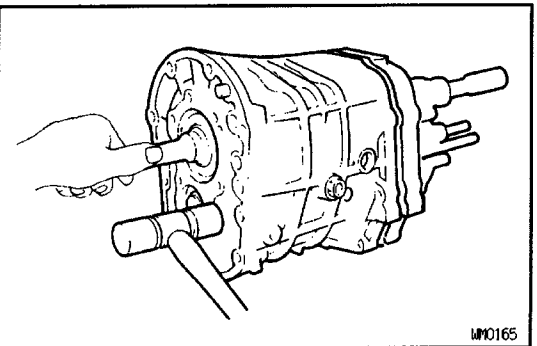

- (c) Align the each bearing outer race and each shift fork shaft end with the case holes.
- (d) Using a plastic hammer, tap on the case to install it.

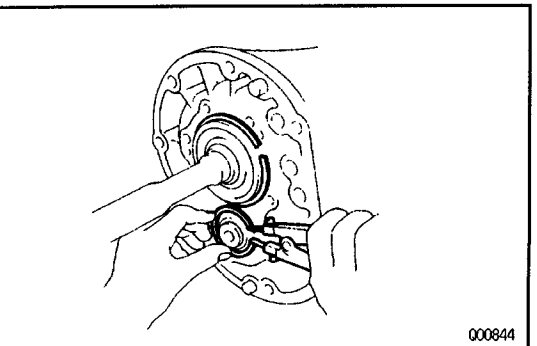

**24. INSTALL BEARING SNAP RINGS**

Using a snap ring expander, install the two snap rings.

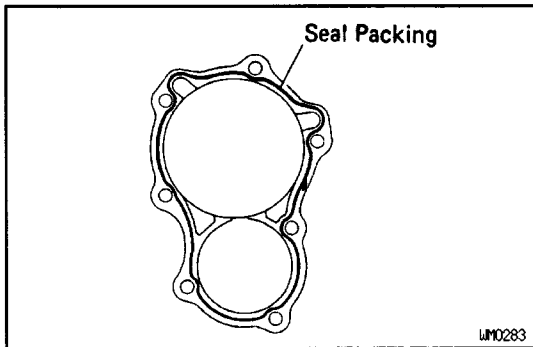

## 25. INSTALL FRONT BEARING RETAINER

- (a) Remove the any packing material and be careful not to drop oil on the contacting surface of the front bearing retainer or transmission case.
- (b) Apply seal packing to the retainer as shown, and install it to the transmission case.

### Seal packing:

**Part No. 08826 – 00090, THREE BOND 1281 or equivalent**

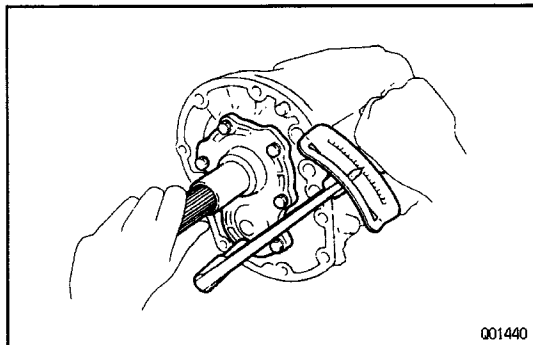

- (c) Apply liquid sealer to the bolt threads.

### Sealant:

**Part No.08833-00080. THREE BOND 1344, LOC-TITE 242 or equivalent**

- (d) Install and torque the bolts.  
**Torque: 25 N-m (250 kgf-cm, 18 ft-lbf)**

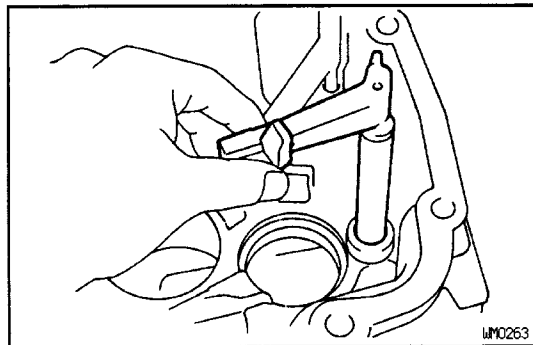

## 26. (2WD)

### INSTALL EXTENSION HOUSING

- (a) Install the shift and select lever into the extension housing.

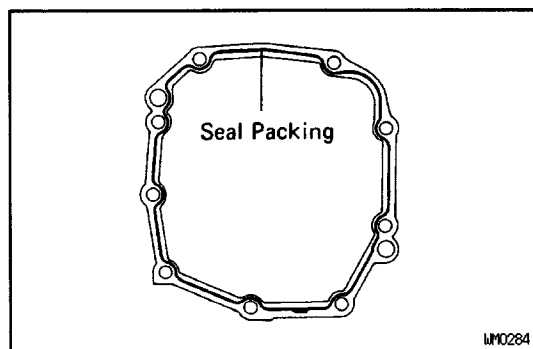

- (b) Remove the any packing material and be careful not to drop oil on the contacting surface of the extension housing or intermediate plate.
- (c) Apply seal packing to the extension housing.

### Seal packing:

**Part No. 08826 – 00090, THREE BOND 1281 or equivalent**

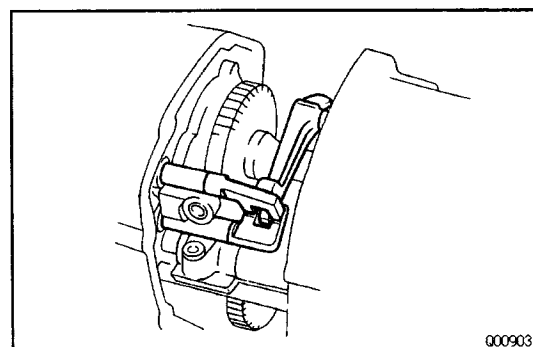

- (d) Connect the shift and select lever to the shift fork shaft.

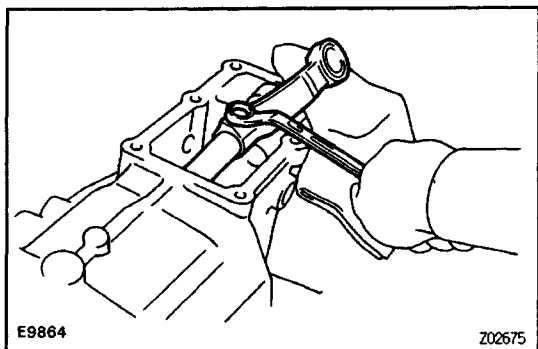

- (e) Install the shift lever housing to the shift and select lever shaft, push in the extension housing.  
 (f) Install and torque the bolt.

**Torque: 39 N-m (400 kgf-cm, 29 ft-lbf)**

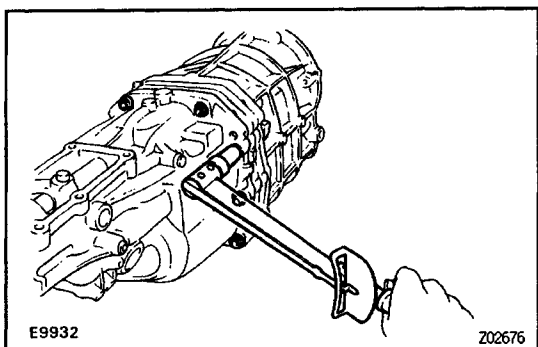

- (g) Install the nine bolts to the extension housing.  
 (h) Torque the bolts.

**Torque: 37 N-m (375 kgf-cm, 27 ft-lbf)**

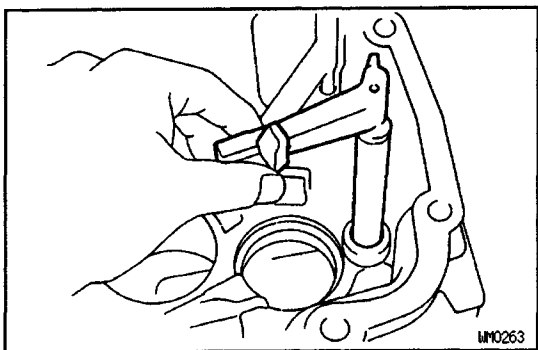

## 27. (4WD)

### INSTALL TRANSFER ADAPTOR

- (a) Install the shift and select lever into the transfer adaptor.

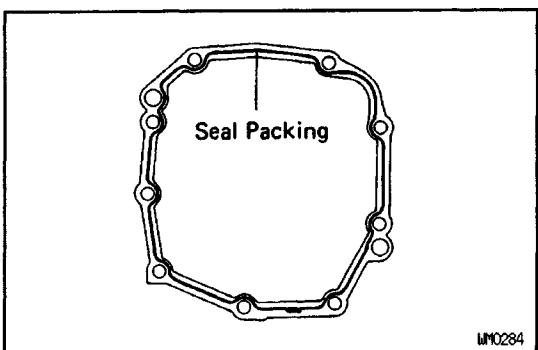

- (b) Remove the any packing material and be careful not to drop oil on the contacting surface of the transfer adaptor or intermediate plate.  
 (c) Apply seal packing to the extension housing.

#### Seal packing:

**Part No. 08826 – 00090, THREE BOND 1281 or equivalent**

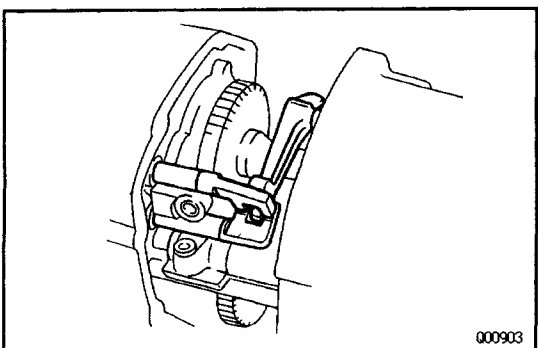

- (d) Connect the shift and select lever to the shift fork shaft.

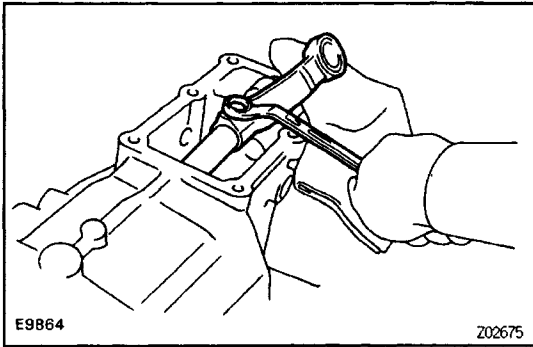

- (e) Install the shift lever housing to the shift and select lever shaft, push in the transfer adaptor.
- (f) Install and torque the bolt.

**Torque: 39 N-m (400 kgf-cm, 29 ft-lbf)**

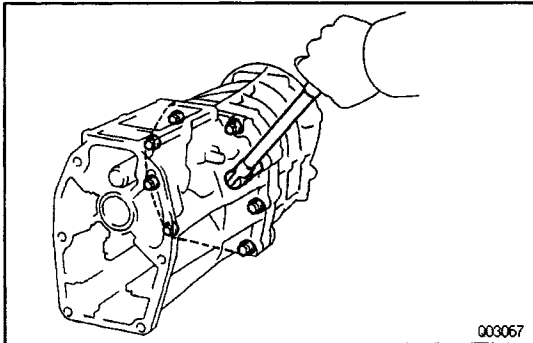

- (g) Install the nine bolts to the transfer adaptor.
- (h) Torque the bolts.

**Torque: 37 N-m (380 kgf-cm, 27ft-lbf)**

## 28. AFTER INSTALLING EXTENSION HOUSING, CHECK FOLLOWING ITEMS:

- (a) Check to see that the input shaft and output shaft rotate smoothly.
- (b) Check to see that shifting can be made smoothly to all positions.

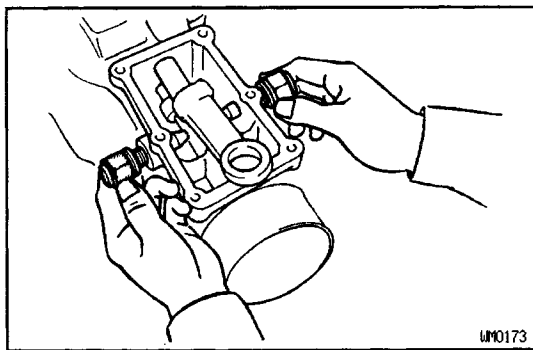

## 29. INSTALL RESTRICT PINS

- (a) Install the restrict pins together with a gasket.
- HINT: Install the black pin on the reverse gear/5th gear side.

- (b) Torque the restrict pins.

**Torque: 40 N-m (410 kgf-cm, 30 ft-lbf)**

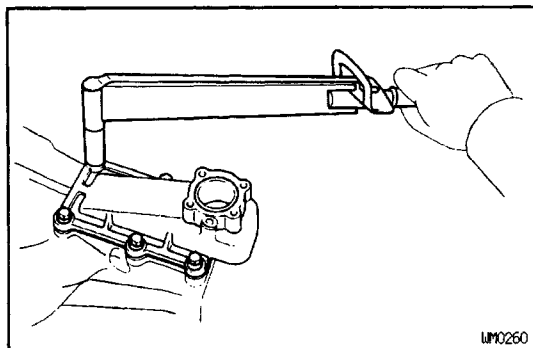

## 30. (2WD)

### INSTALL SHIFT LEVER RETAINER

- (a) Install the shift lever retainer with a oil baffle.
- (b) Install and torque the six bolts.

**Torque: 18 N-m (185 kgf-cm, 13 ft-lbf)**

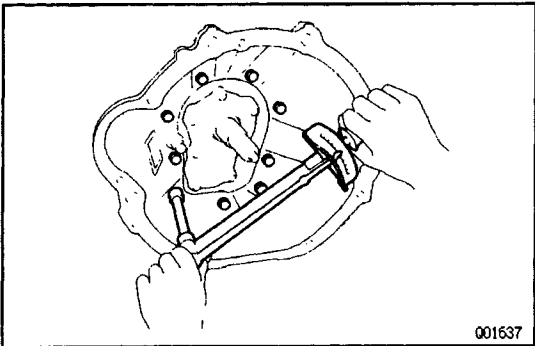
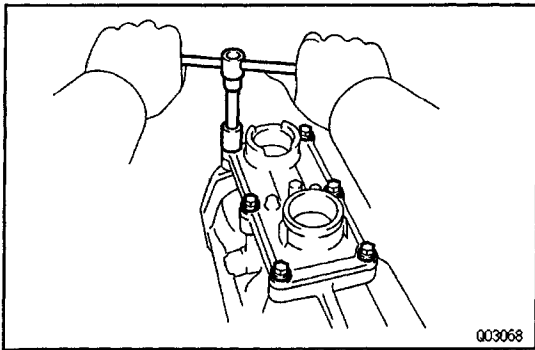

### 31. INSTALL CLUTCH HOUSING

- (a) Install the clutch housing.
- (b) Install and torque the nine bolts.

**Torque: 37 N-m (375 kgf-cm, 27 ft-lbf)**

### 32. INSTALL VEHICLE SPEED SENSOR

- (a) Install the speed sensor.
- (b) Install and torque the set bolt.

**Torque: 13 N-m (130 kgf-cm, 9 ft-lbf)**

### 33. INSTALL BACK-UP LIGHT SWITCH

- (a) Install and torque the back-up light switch.

**Torque: 40 N-m (410 kgf-cm, 30 ft-lbf)**

- (b) Install the wire clamp.