

COUNTER GEAR AND REVERSE IDLER GEAR COMPONENTS

MT00N-02

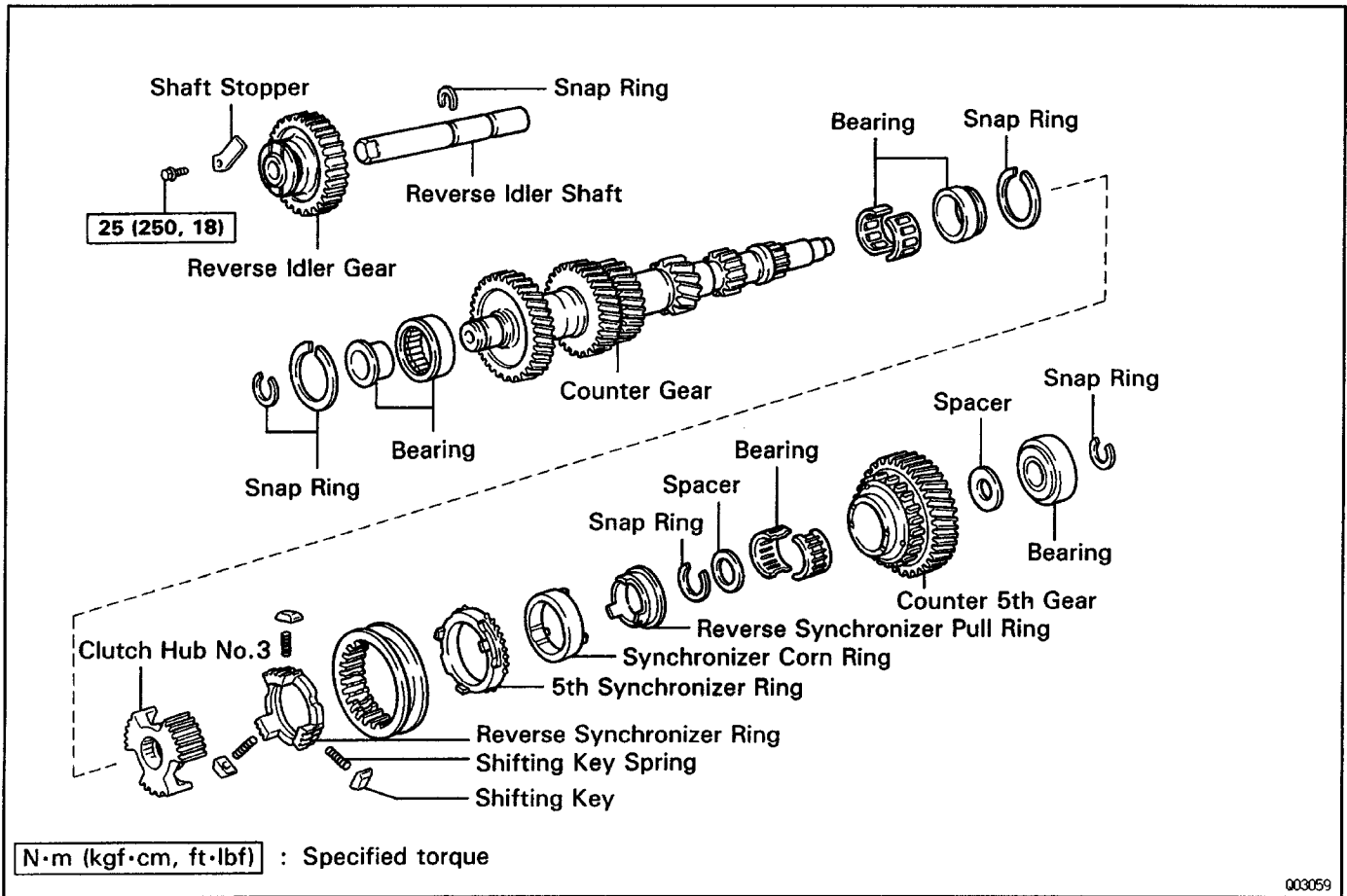

MT00P-02

COUNTER GEAR COMPONENT PARTS DISASSEMBLY

1. REMOVE NO.3 HUB SLEEVE, SHIFTING KEYS AND SPRINGS FROM SYNCHRONIZER RING

(a) Remove the synchronizer ring assembly from No.3 hub sleeve.

(b) Turn the reverse synchronizer pull ring.

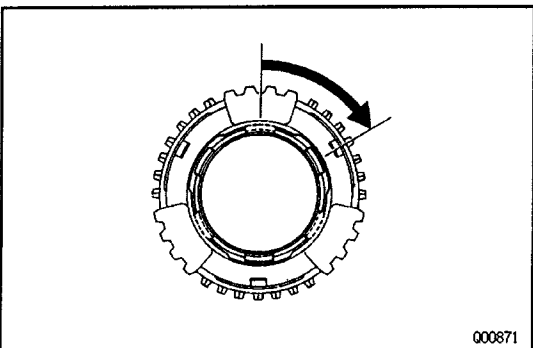
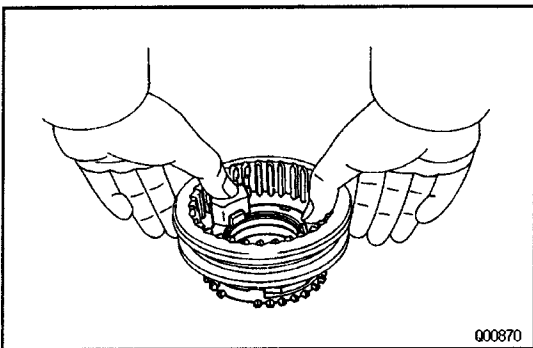

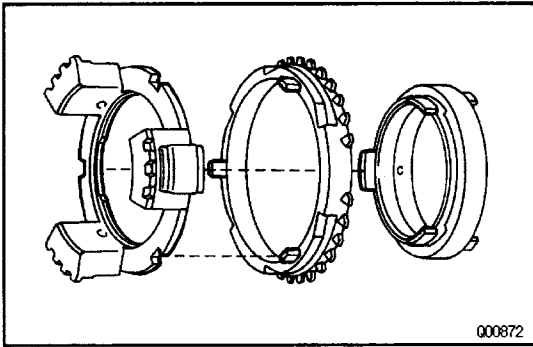

- (c) Remove the reverse synchronizer ring and 5th synchronizer ring.

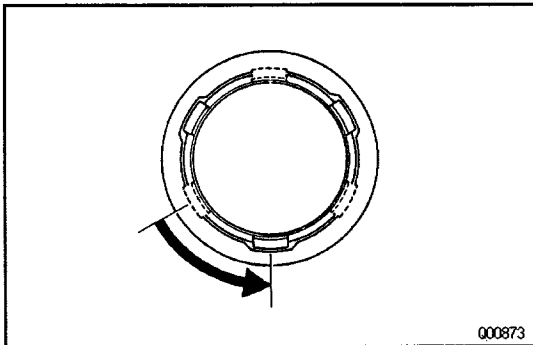

- (d) Turn the reverse synchronizer pull ring, separate pull ring and corn ring.

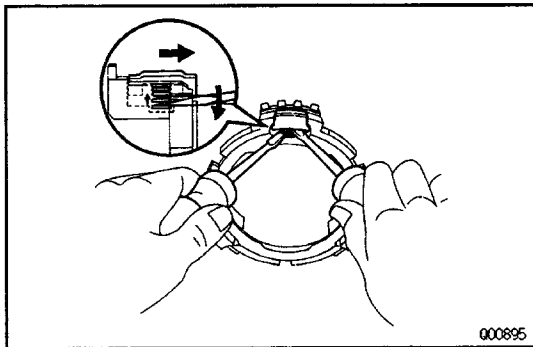

- (e) While pushing the shifting key spring to out slide with two screwdrivers, remove the shifting keys and key springs, from remove synchronizer ring.

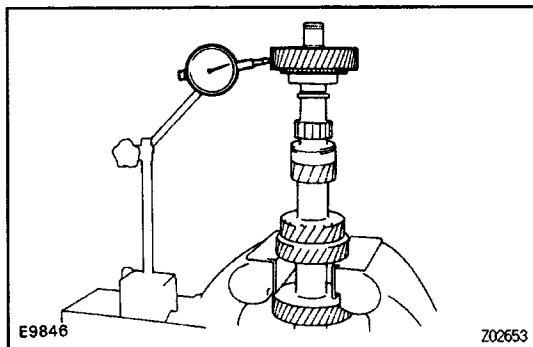

COUNTER GEAR AND REVERSE IDLER GEAR COMPONENT PARTS INSPECTION

1. INSPECT COUNTER 5TH GEAR OIL CLEARANCE

- (a) Install the spacer, counter 5th gear and needle roller bearing to counter gear.
- (b) Using a dial indicator, measure the counter 5th gear oil clearance.

Standard clearance:

0.009–0.06 mm (0.0004–0.0024 in.)

Maximum clearance:

0.15 mm (0.0059 in.)

If the clearance exceeds the maximum, replace the counter gear or needle roller bearing or counter 5th gear.

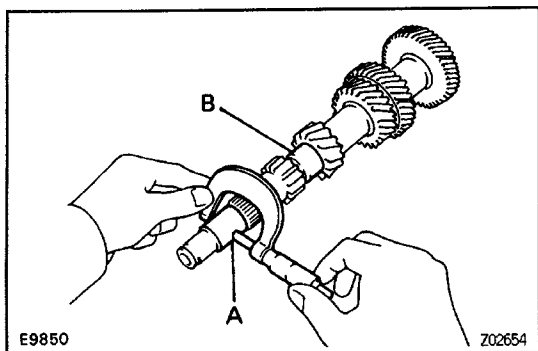

2. INSPECT COUNTER GEAR

Using a micrometer, measure the outer diameter of the counter shaft journal.

Minimum diameter:

Part A

26.975 mm (1.0620 in.)

Part B

29.95 mm (1.1791 in.)

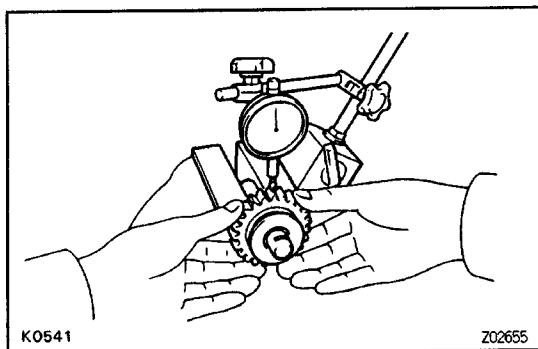

3. INSPECT REVERSE IDLER GEAR OIL CLEARANCE

Using a dial indicator, measure the reverse idler gear oil clearance.

Standard clearance:

0.041–0.074 mm (0.0016–0.0029 in.)

Maximum clearance:

0.194 mm (0.0076 in.)

If the clearance exceeds the maximum, replace the gear or shaft.

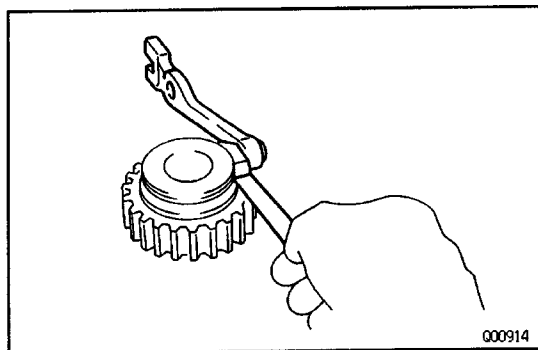

4. INSPECT CLEARANCE OF REVERSE IDLER GEAR AND SHIFT ARM SHOE

Using a feeler gauge, measure the clearance between the reverse idler gear and shift arm shoe.

Standard clearance:

0.20–0.41 mm (0.008–0.0161 in.)

Maximum clearance:

0.9 mm (0.0354 in.)

If the clearance exceeds the maximum, replace the shift arm shoe or reverse idler gear.

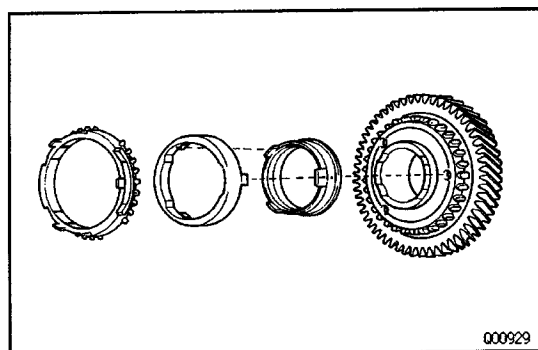

5. INSPECT FIFTH SYNCHRONIZER RING

- (a) Check for wear or damage.
- (b) Install the synchronizer pull ring, corn ring and outer ring to 5th gear.

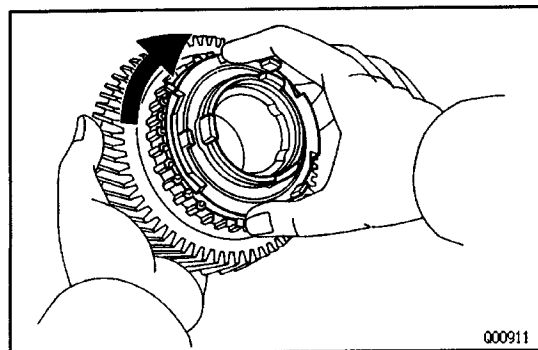

- (c) Check the braking effect of the synchronizer ring. Turn the synchronizer ring in one direction while pushing it to the gear cone and check that the ring is locked. If the backing effect is insufficient, replace the synchronizer rings.

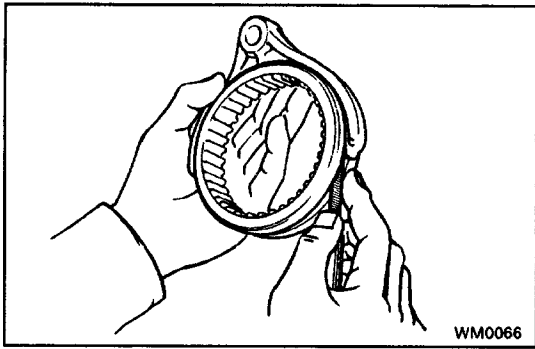

6. INSPECT CLEARANCE OF SHIFT FORKS AND HUB SLEEVES

Using a feeler gauge, measure the clearance between the hub sleeve and shift fork.

Maximum clearance:

1.0 mm (0.039 in.)

If the clearance exceeds the maximum, replace the shift fork or hub sleeve.

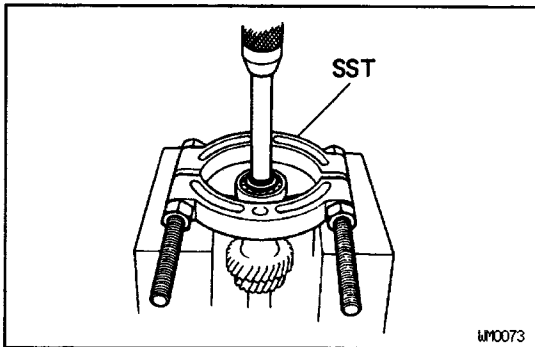

BEARING REPLACEMENT

MT00R-02

1. IF NECESSARY, REPLACE COUNTER GEAR FRONT BEARING AND SIDE RACE

(a) Using snap ring pliers, remove the snap ring.

(b) Using SST, press out the bearing.

SST 09950-00020

(c) Check the side race for wear or damage.

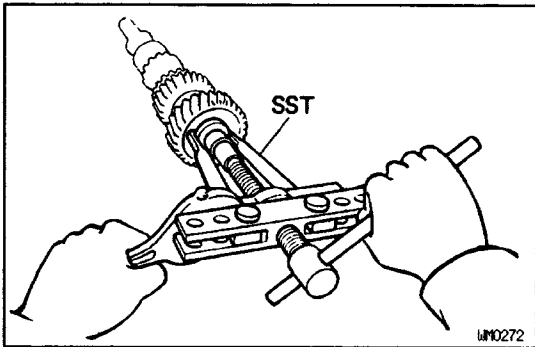

(d) If necessary, remove the side race.

Using SST and socket wrench, remove the side race.

SST 09950-20017

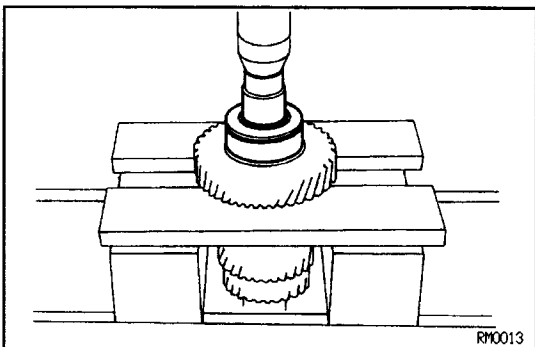

(e) Using a socket wrench, press in a new bearing, side race and inner race.

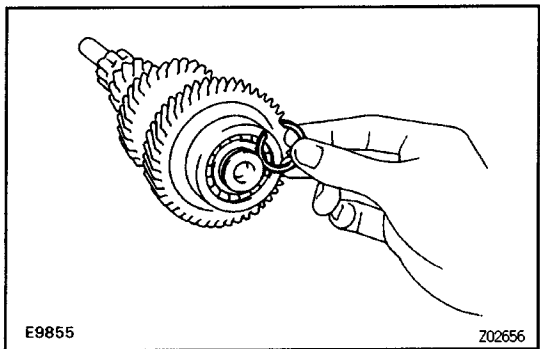

(f) Select a snap ring that will allow minimum axial play.

Mark	Thickness mm (in.)
A	2.05-2.10 (0.0807-0.0827)
B	2.10-2.15 (0.0827-0.0846)
C	2.15-2.20 (0.0846-0.0866)
D	2.20-2.25 (0.0866-0.0886)
E	2.25-2.30 (0.0886-0.0906)
F	2.30-2.35 (0.0906-0.0925)

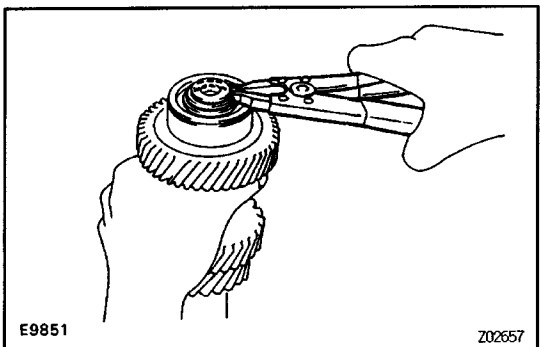

(g) Using a snap ring expander, install the snap ring.

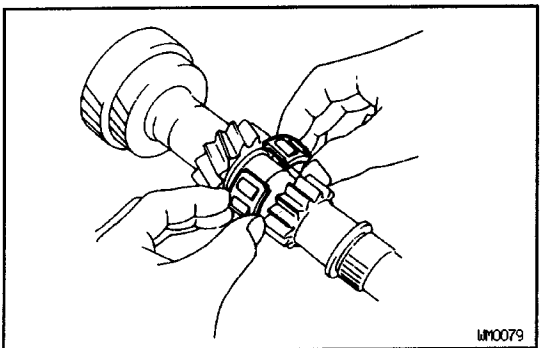

2. IF NECESSARY, REPLACE COUNTER GEAR CENTER BEARING

- (a) Remove the bearing from the counter gear.
- (b) Install a new bearing on the counter gear.

HINT: Engage the roller cages.

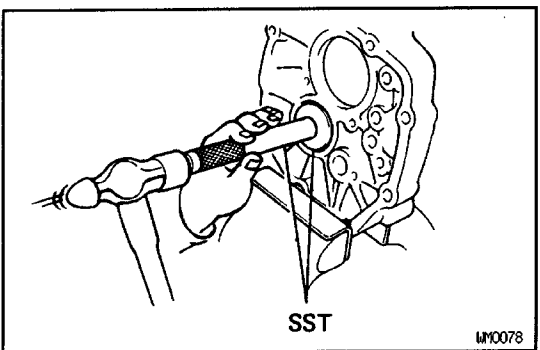

(c) Using SST, tap out the bearing outer race.

SST 09608-35014 (09608-06020, 09608-06090)

HINT: The outer race will be installed later, as the transmission is assembled.

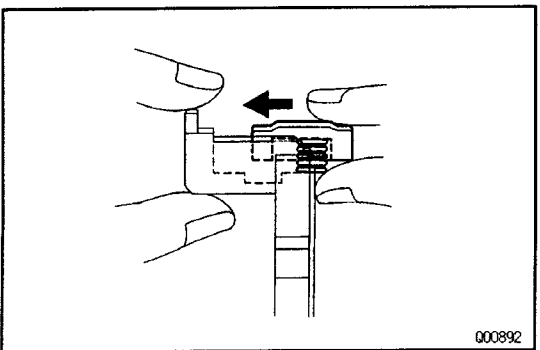

COUNTER GEAR COMPONENT PARTS ASSEMBLY

1. INSTALL SYNCHRONIZER RING ASSEMBLY TO NO.3 HUB SLEEVE

- (a) Push the synchronizer spring, install the shifting key and key spring to reverse synchronizer ring.

MT008-02

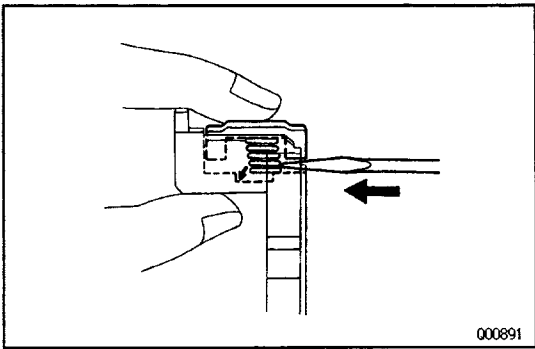

(b) Using a screwdriver, push the three key springs into the synchronizer ring spring gear.

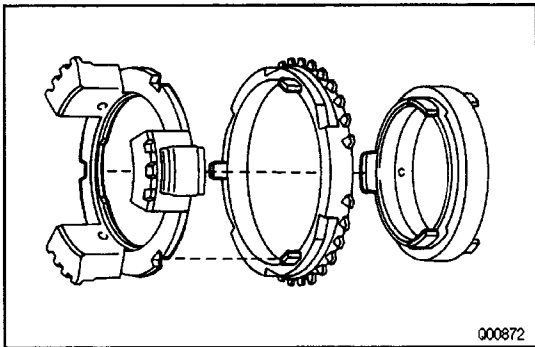

(c) Install the synchronizer corn ring to reverse synchronizer pull ring.

(d) Install the 5th synchronizer ring.

(e) Install the reverse synchronizer ring.

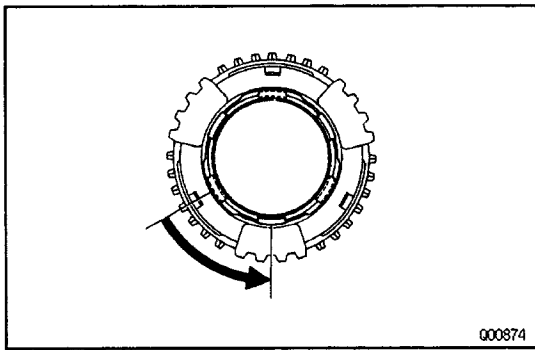

(f) Turn the reverse synchronizer pull ring.

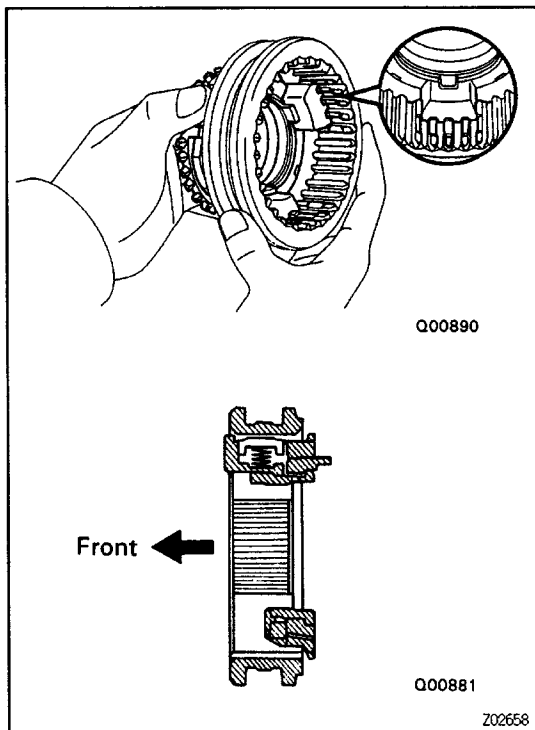

(g) While pushing three shifting keys, install the synchronizer ring assembly to No.3 hub sleeve.