

Disassembly of Transmission

(See pages [MT1–67](#), 68)

1. REMOVE RELEASE FORK AND BEARING
2. REMOVE BACK-UP LIGHT SWITCH, SPEEDOMETER DRIVEN GEAR (2WD). SHIFT LEVER RETAINER AND RESTRICT PINS
3. REMOVE CLUTCH HOUSING FROM TRANSMISSION CASE
4. REMOVE STRAIGHT SCREW PLUG, SPRING AND BALL

(a) Using a torx socket wrench, remove the screw plug from the extension housing or transfer adaptor.
(Torx socket wrench T40 09042–00020)

(b) Using a magnetic finger, remove the spring and ball.

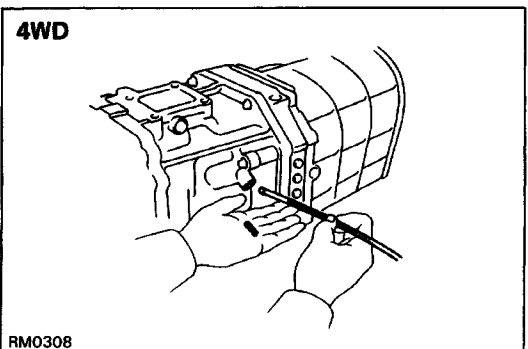
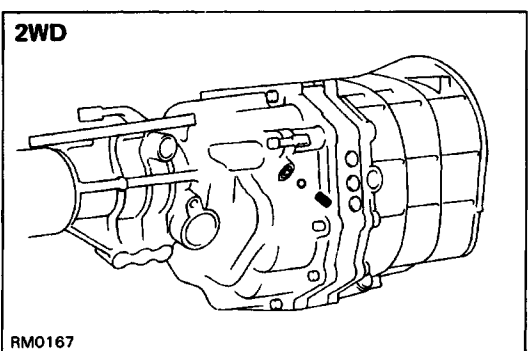
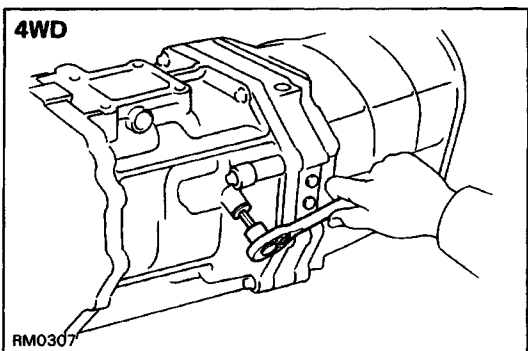
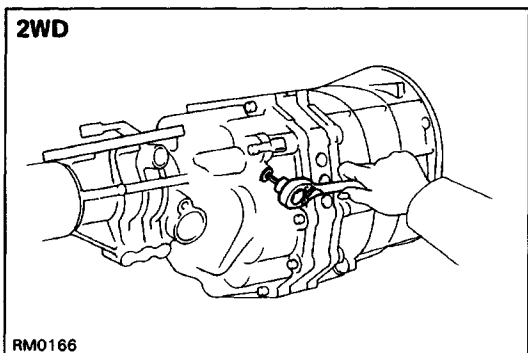
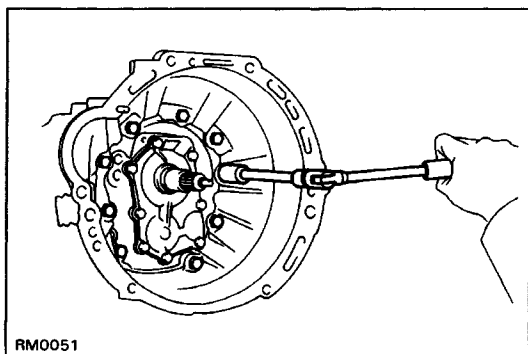

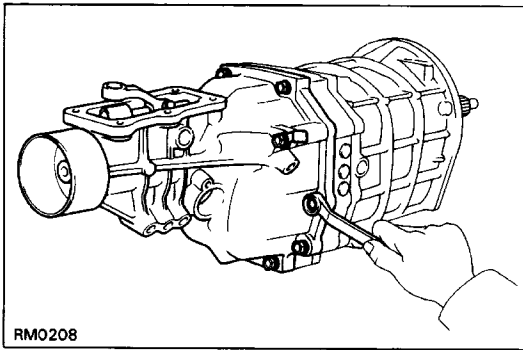

RM0208

5.-1 (2WD) REMOVE EXTENSION HOUSING

(a) Remove the ten bolts.

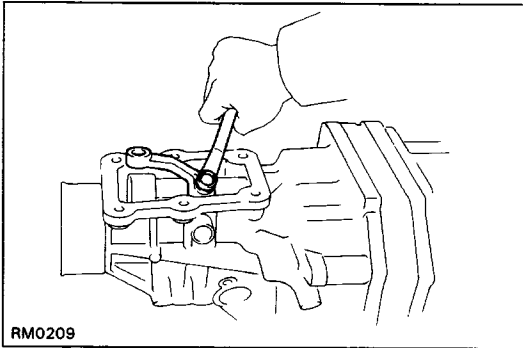

RM0209

(b) Remove the shift lever housing set bolt.

(c) Using a plastic hammer, tap the extension housing and remove the shift lever housing and shift and select lever.

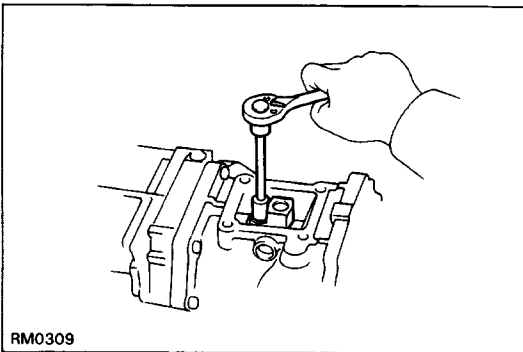

RM0309

5.-2 (4WD) REMOVE TRANSFER ADAPTOR

(a) Remove the shift lever housing set bolt.

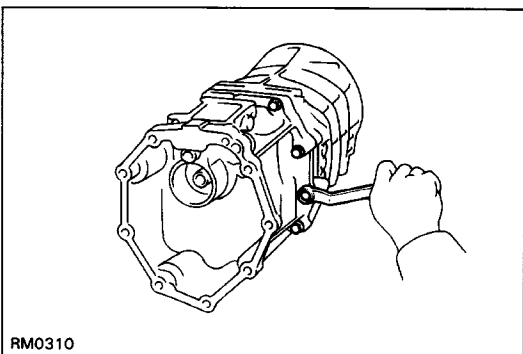

RM0310

(b) Remove the ten bolts.

(c) Using a plastic hammer, tap the transfer adaptor and remove the shift lever housing and shift and select lever.

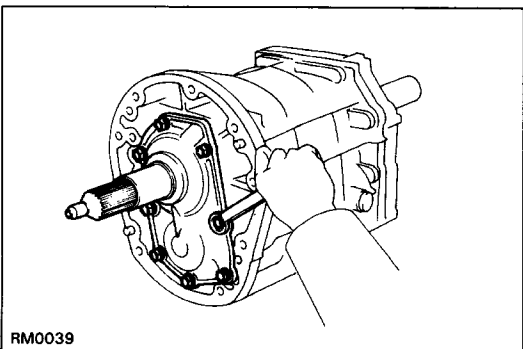

RM0039

6. REMOVE FRONT BEARING RETAINER

(a) Remove the eight bolts.

(b) Using a plastic hammer, tap the front bearing retainer.

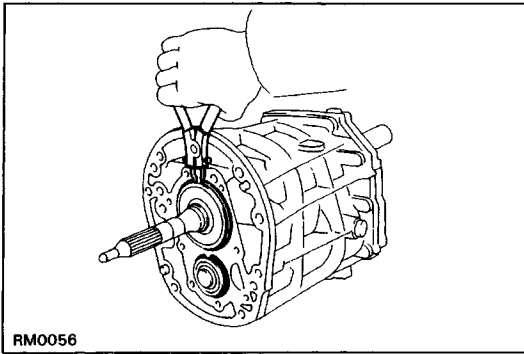

7. REMOVE BEARING SNAP RINGS

Using a snap ring expander, remove the two snap rings.

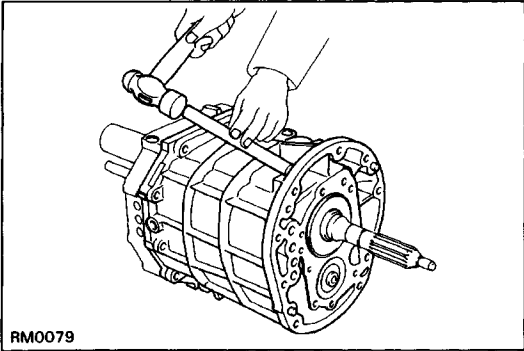

8. SEPARATE INTERMEDIATE PLATE FROM TRANSMISSION CASE

- (a) Using a brass bar and hammer, carefully tap off the transmission case.
- (b) Remove the transmission case from the intermediate plate.

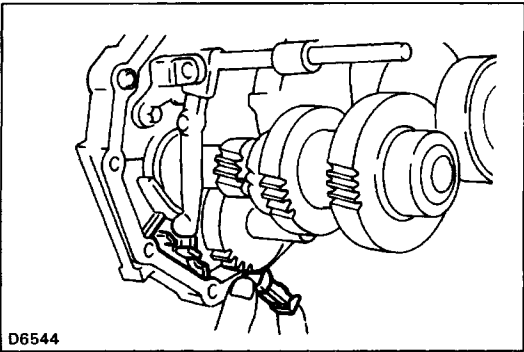

9. REMOVE MAGNET FROM INTERMEDIATE PLATE

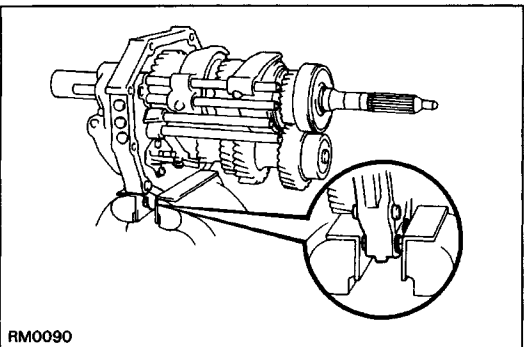

10. MOUNT INTERMEDIATE PLATE IN VISE

- (a) Use two clutch housing bolts, plate washers and suitable nuts as shown.

NOTICE: Install the plate washers in reverse of normal. Increase or decrease plate washers so that the bolt tip and front tip surface of the nut are aligned.

- (b) Mount the intermediate plate in a vise.

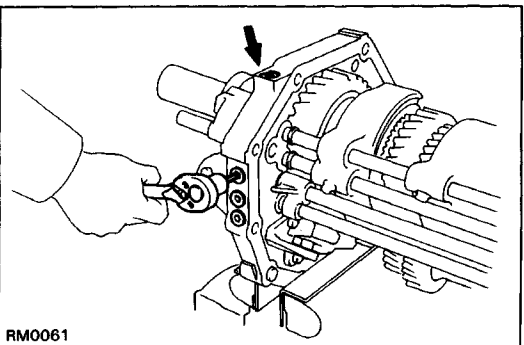

11. REMOVE STRAIGHT SCREW PLUGS, LOCKING BALLS AND SPRINGS

- (a) Using a torx socket wrench, remove the four plugs.
(Torx socket wrench T40 09042-00020)

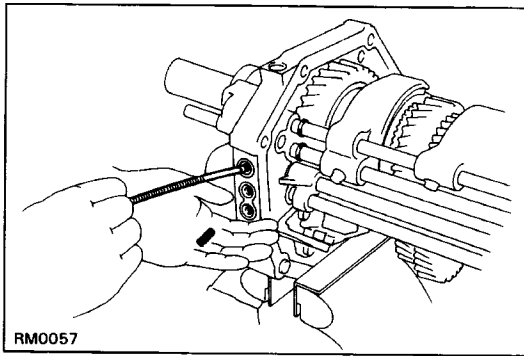

(b) Using a magnetic finger, remove the four springs and balls.

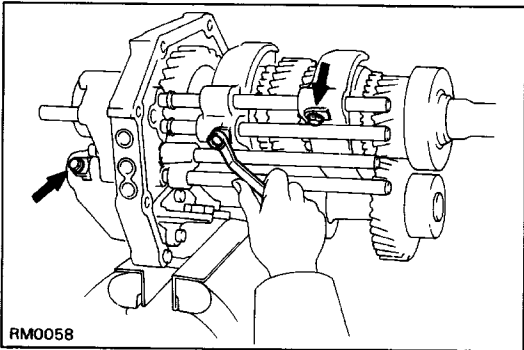

12. REMOVE SHIFT FORK SET BOLTS

Remove the three bolts.

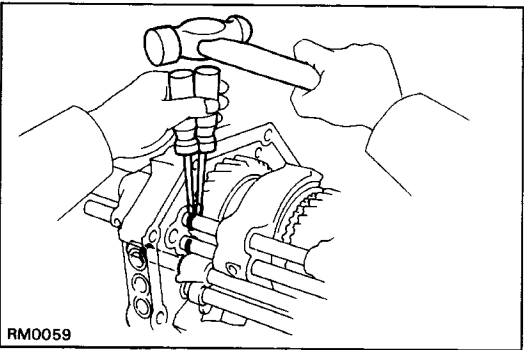

13. REMOVE SNAP RINGS

Using two screwdrivers and a hammer, tap out the three snap rings.

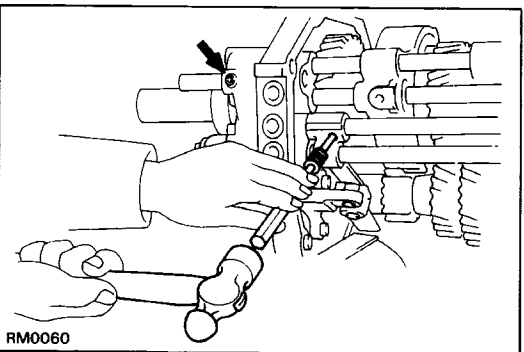

14. REMOVE SLOTTED SPRING PINS

Using a pin punch and hammer, drive out the two pins.

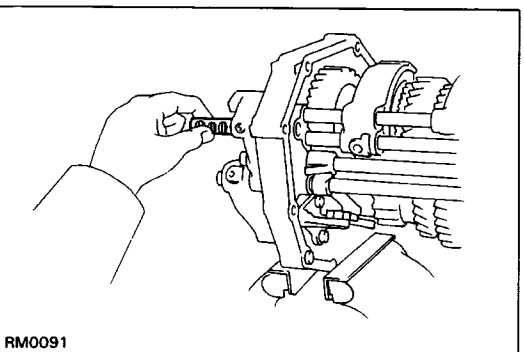

15. REMOVE SHIFT FORK SHAFT NO.5

Pull out the shift fork shaft No.5 from the intermediate plate.

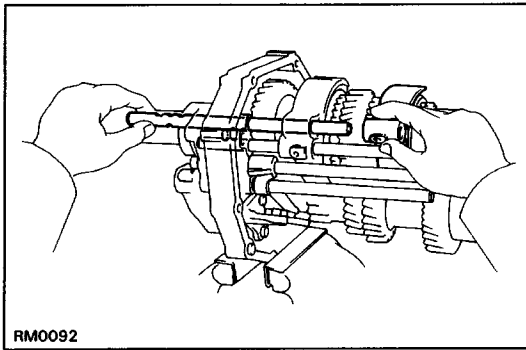

16. REMOVE SHIFT FORK SHAFT NO.2 AND SHIFT FORK

- (a) Pull out the shift fork shaft No. 2 from the intermediate plate.
- (b) Remove the shift fork No.2.
- (c) Using a magnetic finger, remove the interlock pin from the intermediate plate.

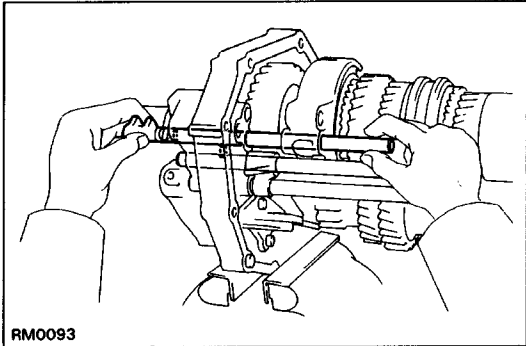

17. REMOVE SHIFT FORK SHAFT NO. 1

- (a) Pull out the shift fork shaft No. 1 from the intermediate plate.
- (b) Using a magnetic finger, remove the interlock pins from the shaft hole and intermediate plate.

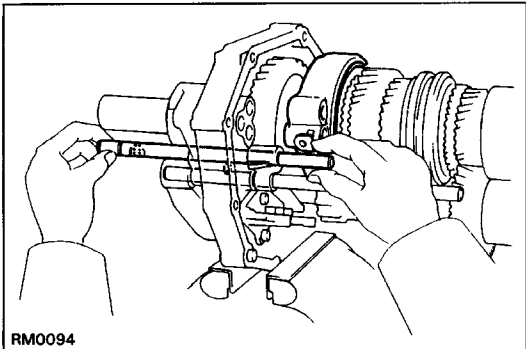

18. REMOVE SHIFT FORK SHAFT NO.3 AND SHIFT FORK NO. 1

- (a) Pull out the shift fork shaft No.3 from the intermediate plate.
- (b) Remove the shift fork No. 1.
- (c) Using a magnetic finger, remove the interlock pin and locking ball from the shaft hole and intermediate plate.

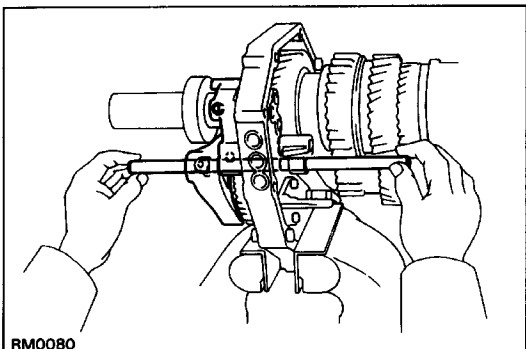

19. REMOVE SHIFT FORK SHAFT NO.4, SHIFT FORK NO.3 AND REVERSE SHIFT HEAD

- (a) Pull out the shift fork shaft No.4 from the intermediate plate.
- (b) Remove the reverse shift head and locking ball.
- (c) Remove the shift fork No.3.

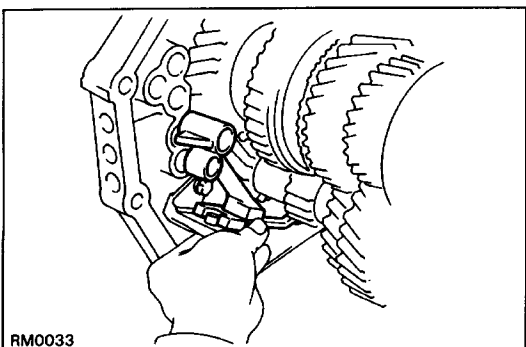

20. REMOVE REVERSE SHIFT ARM FROM REVERSE SHIFT ARM BRACKET

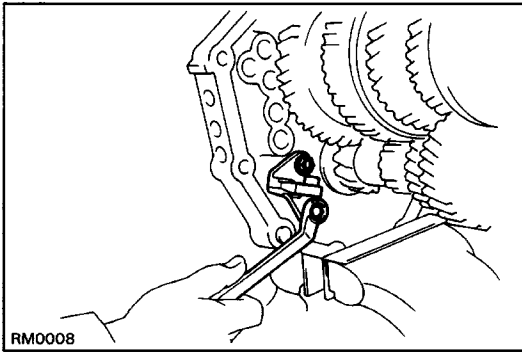
**21. REMOVE REVERSE SHIFT ARM BRACKET**

Remove the two bolts and the reverse shift arm bracket.

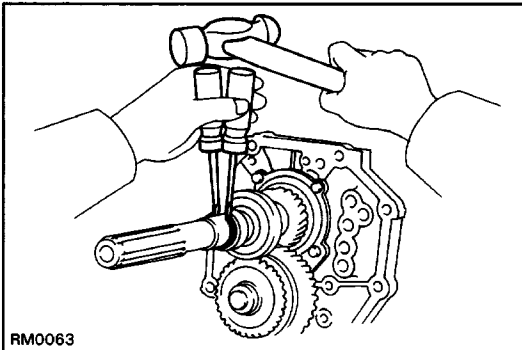
**22.-1 (2WD)****REMOVE SPEEDOMETER DRIVE GEAR**

- (a) Using two screwdrivers and a hammer, tap out the rear snap ring.
- (b) Remove the speedometer drive gear and ball.
- (c) Using two screwdrivers and a hammer, tap out the front snap ring.

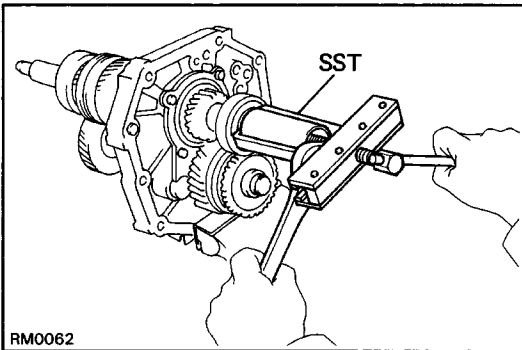
**22.-2 (4WD)****REMOVE SLEEVE FROM OUTPUT SHAFT**

Using SST, remove the sleeve from the output shaft.
SST 09213-36020

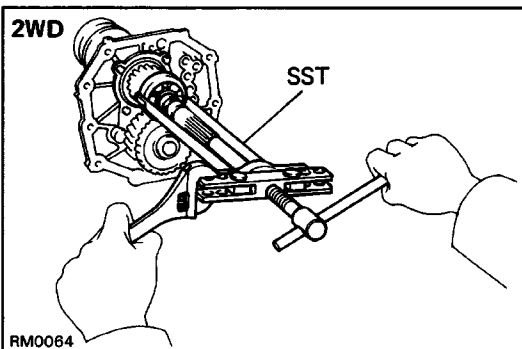
**23. REMOVE OUTPUT SHAFT REAR BEARING**

- (a) Using two screwdrivers and a hammer, tap out the snap ring.
- (b) Using SST, remove the rear bearing.
SST 09950-20017

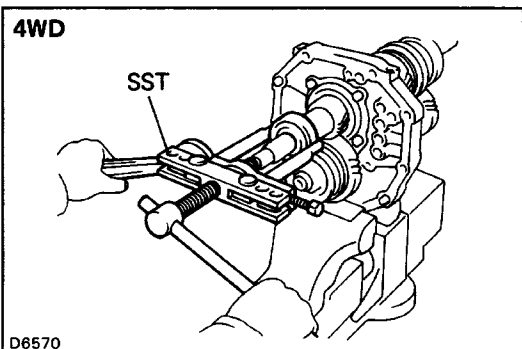

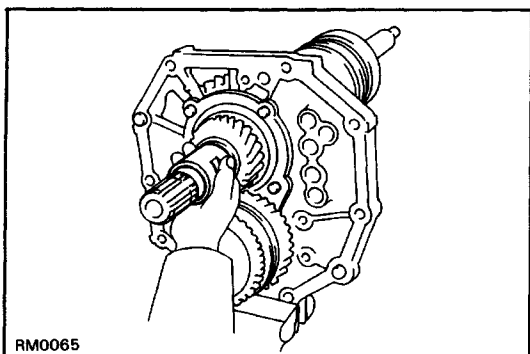

24. REMOVE SPACER

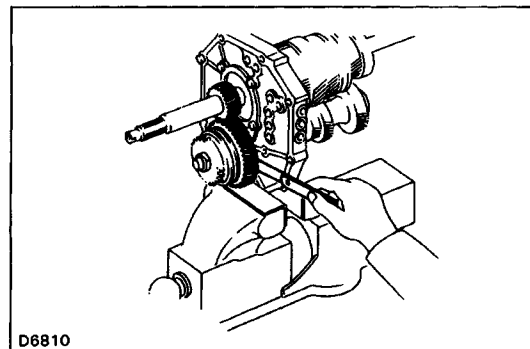

25. MEASURE COUNTER FIFTH GEAR THRUST CLEARANCE

Using a feeler gauge, measure the counter 5th gear thrust clearance.

Standard clearance: 0.10 – 0.35 mm
(0.0039 – 0.0138 in.)

Maximum clearance: 0.40 mm (0.0157 in.)

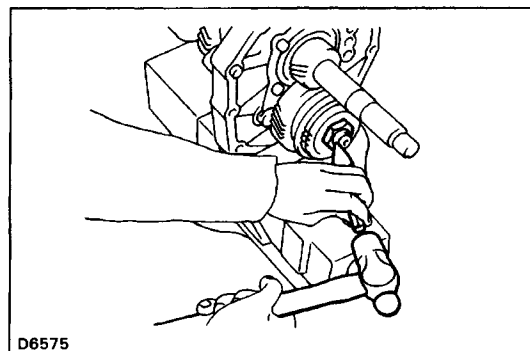

26. REMOVE GEAR SPLINE PIECE NO.5, SYNCHRONIZER RING, NEEDLE ROLLER BEARING AND COUNTER FIFTH GEAR WITH HUB SLEEVE NO.3

- (a) Engage the gear double meshing.
- (b) Using a hammer and chisel, loosen the staked part of the nut.

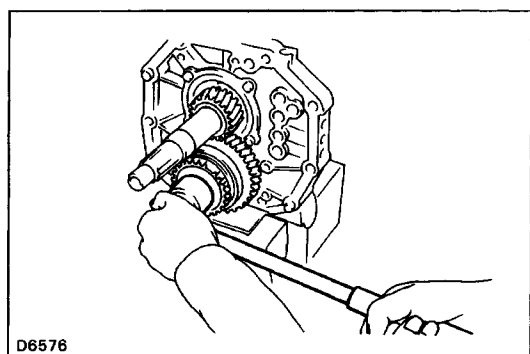

- (c) Remove the lock nut.
- (d) Disengage the gear double meshing.

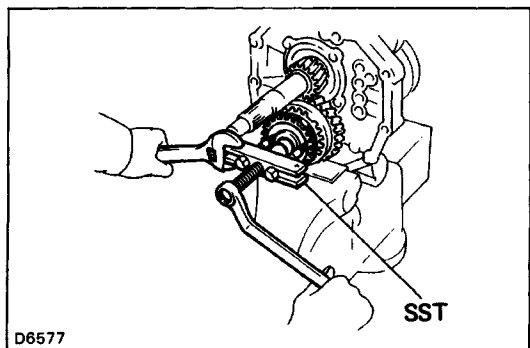

- (e) Using SST, remove the gear spline piece No. 5.
SST 09213-31021
- (f) Remove the counter 5th gear with hub sleeve No-3.

27. REMOVE THE SHIFTING KEYS AND SPRINGS FROM FIFTH GEAR AND HUB SLEEVE NO.3

Using a screwdriver, remove the three shifting keys and two rings.^{sp}

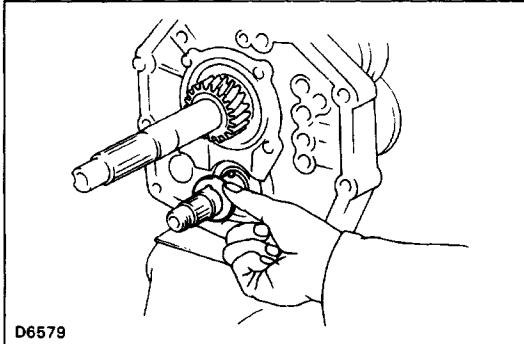
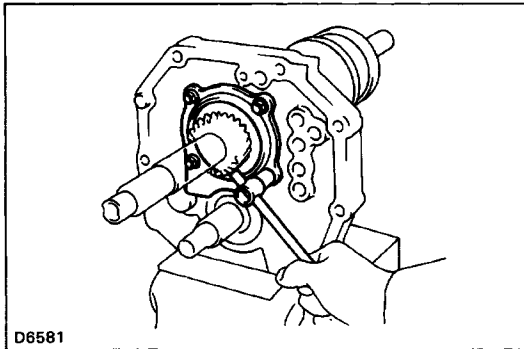
**28. REMOVE THRUST WASHER AND BALL****29. REMOVE REAR BEARING RETAINER**

Remove the four bolts and rear bearing retainer.

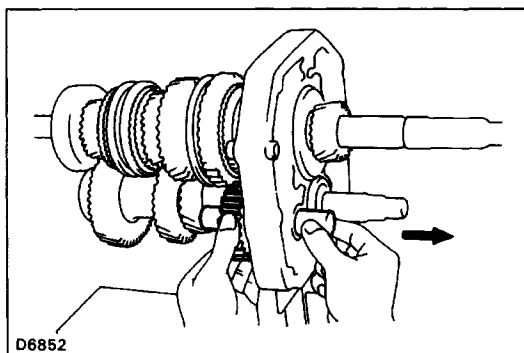
**30. REMOVE REVERSE IDLER GEAR AND SHAFT**

Pull out the shaft toward the rear.

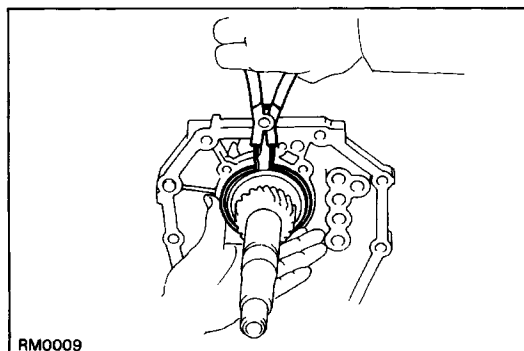
**31. REMOVE BEARING SNAP RING**

Using a snap ring expander, remove the snap ring.

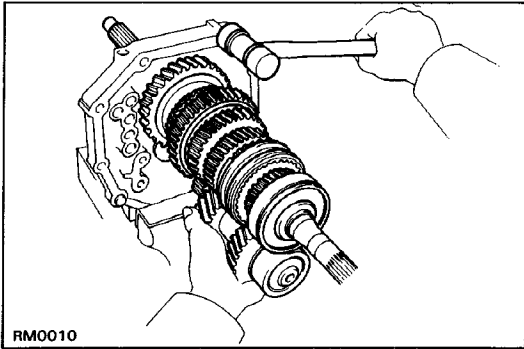

32. REMOVE OUTPUT SHAFT, COUNTER GEAR AND INPUT SHAFT AS A UNIT FROM INTERMEDIATE PLATE

- (a) Remove the output shaft, counter gear and input shaft as a unit from the intermediate plate by pulling on the counter gear and tapping on the intermediate plate with a plastic hammer.
- (b) Remove the input shaft with the needle roller bearing from the output shaft.

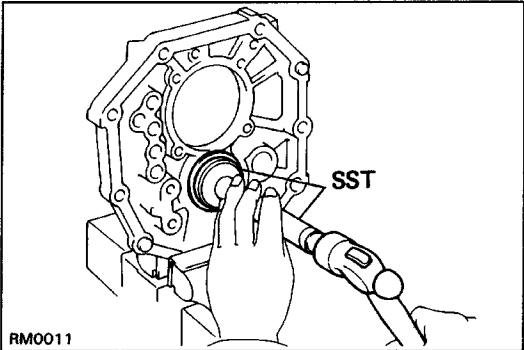

33. REMOVE COUNTER REAR BEARING FROM INTERMEDIATE PLATE

Using SST and a hammer, remove the counter rear bearing.

SST 09608-12010 (09608-00020, 09608-00050)

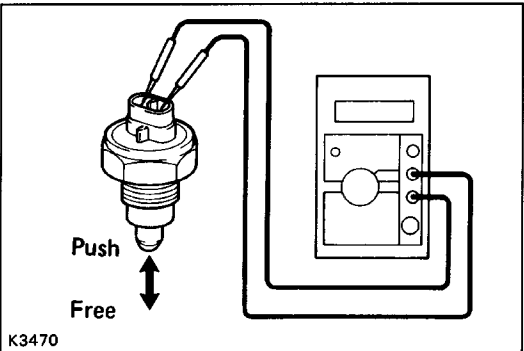

34. INSPECT BACK-UP LIGHT SWITCH

Check that there is continuity between terminals.

Switch Position	Specified
Push	Continuity
Free	No Continuity

If operation is not as specified replace switch.