

DISASSEMBLY OF TRANSMISSION (G58 TRANSMISSION) Components

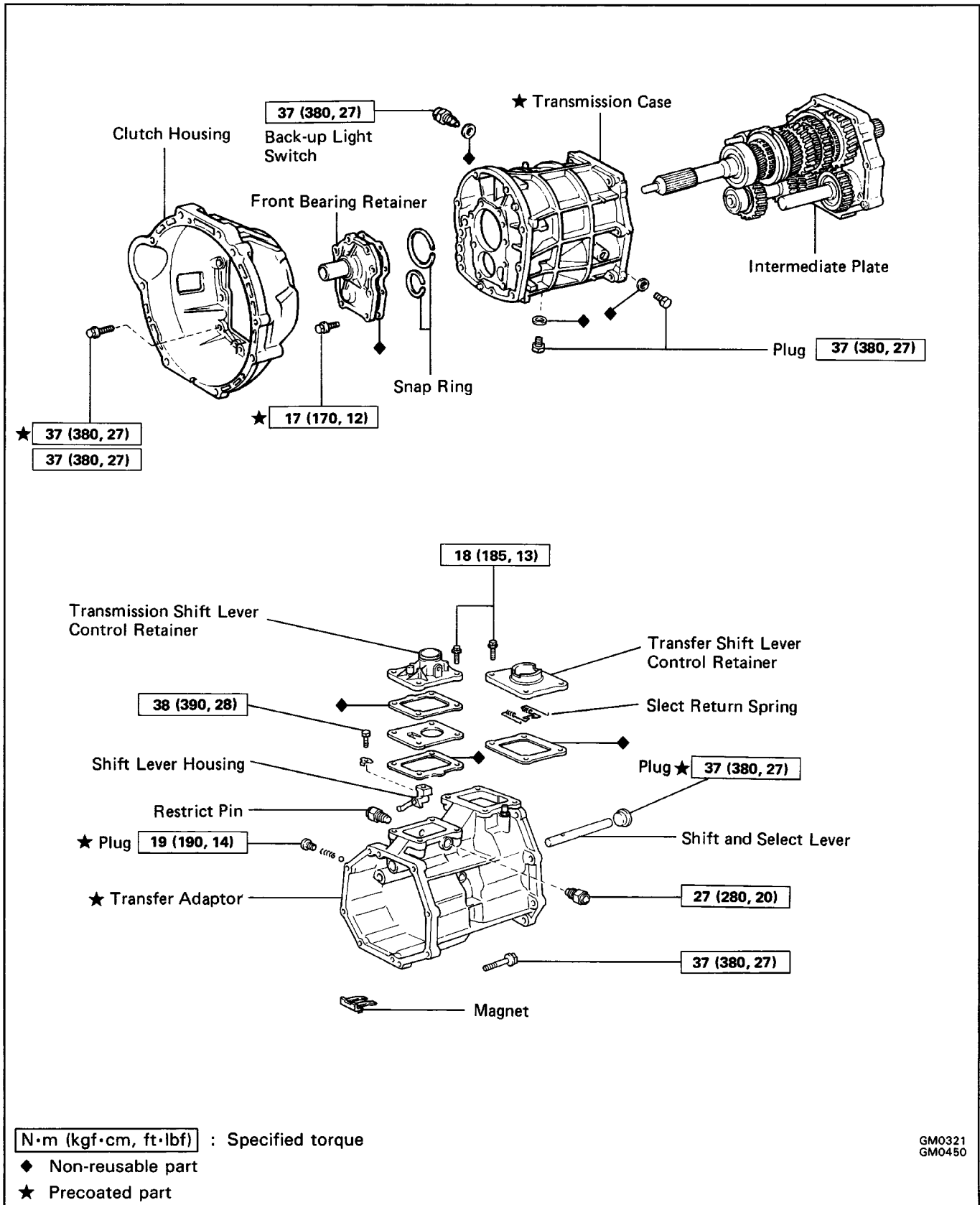

Components (Cont'd)

2WD

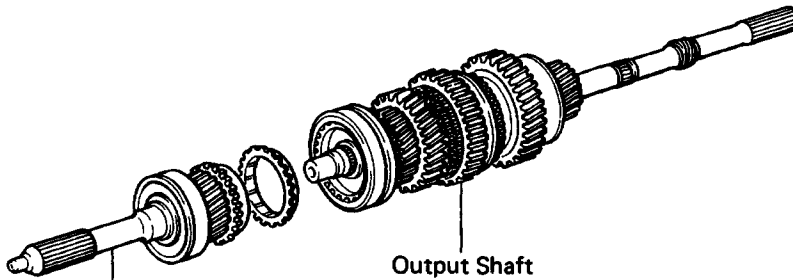

4WD

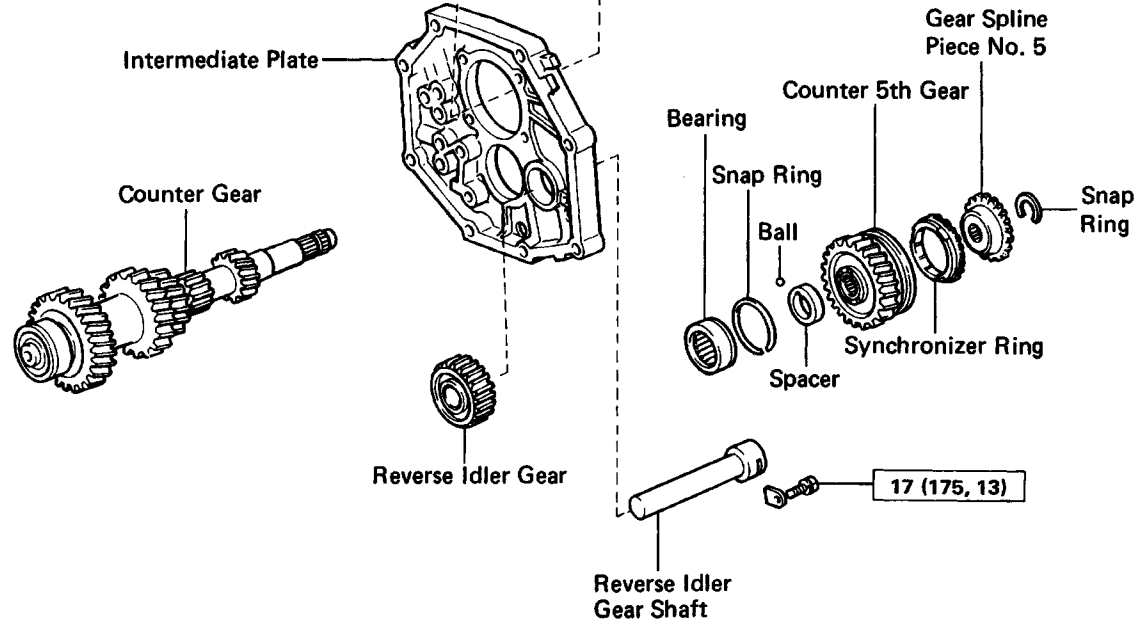
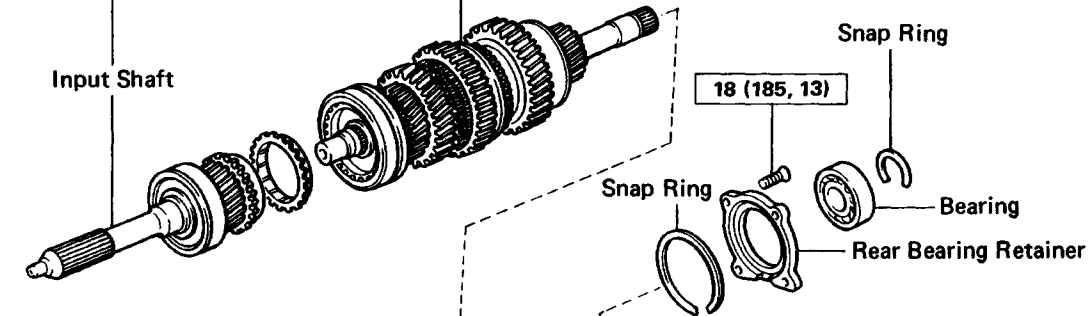

N·m (kgf·cm, ft·lbf) : Specified torque

